

CORNER ELEMENTS

All Resin Ornamentation is Flexible, Stainable & Paintable.



CORNER ELEMENTS

Pearlworks, Inc. 14251 Franklin Ave. Tustin, CA 92780

Office: (714) 573-1700 Fax: (714) 573-1708 Toll Free: (855) PEARLWORKS

www.pearlworksinc.com

CORNER ELEMENTS

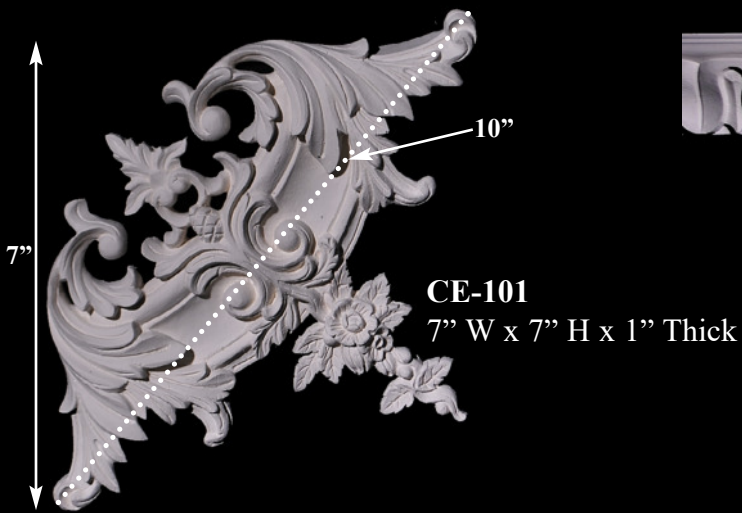

CORNER ELEMENTS

made for connection mouldings

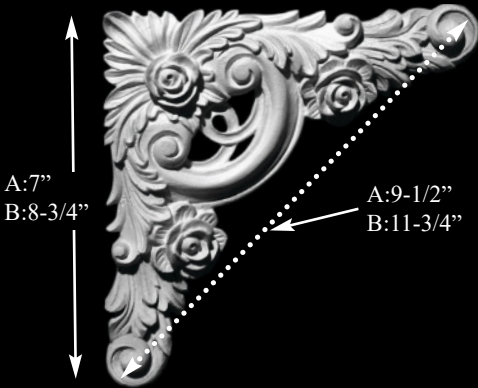

CE-100A
7" x 7" x 5/8"

CE-100B
8-3/4" x 8-3/4" x 1"

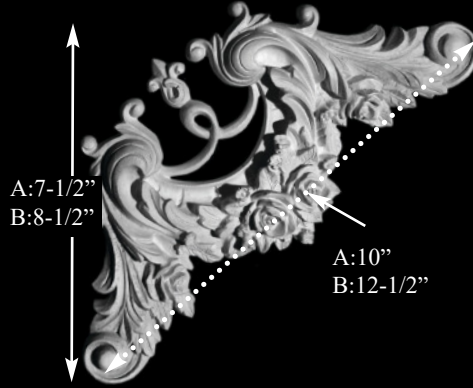

CE-104A
7-1/4" x 7-1/4" x 1"

CE-104B
9" x 9" x 1-1/8"

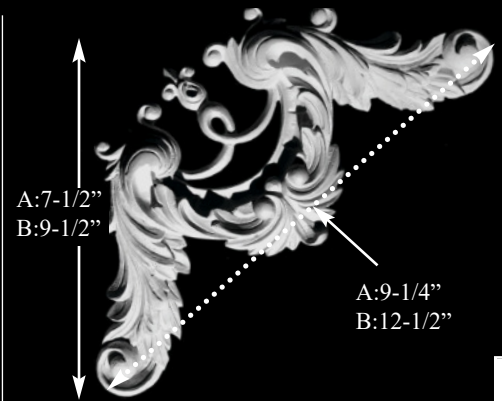

CE-130A
7-1/4" x 7-1/4" x 7/8"

CE-130B
9-1/4" x 9-1/4" x 1"

Any 3/4" - 1" wide connection moulding will work with "A" size corner element.

* Most popular designs for corner elements.

Any 1-1/4" - 1-1/2" wide connection moulding will work with "B" size corner element.

* Most popular designs for corner elements.



MLD-103C



MLD-B111B



MLD-116B



MLD-119CL



MLD-123C



MLD-212A

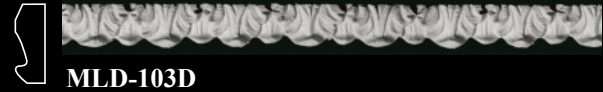

MLD-103D



MLD-B111C



MLD-B116A



MLD-119DL



MLD-123D



MLD-212B

* All sizes are approx. - max W" x max H" x Thickness"

CORNER ELEMENTS



CE-103
8" x 23" x 1"

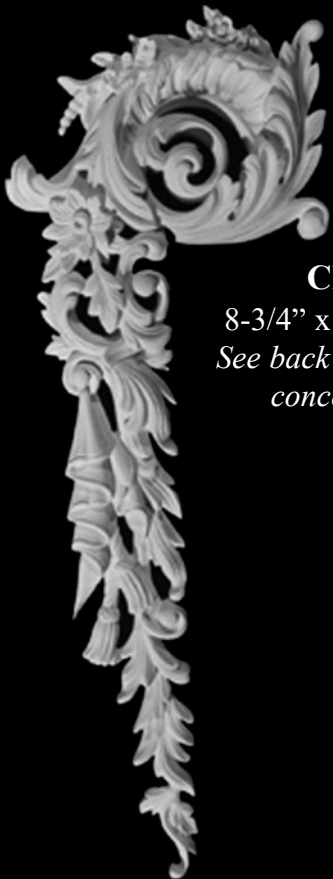

CE-107
8-3/4" x 23-1/2" x 1"
*See back of section for
concept ideas.*

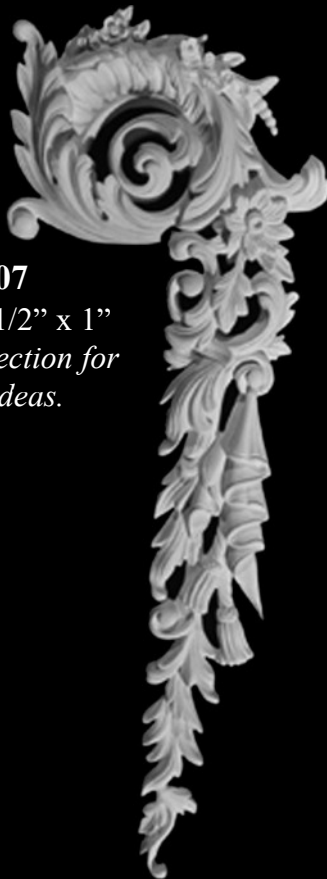

CORNER ELEMENTS

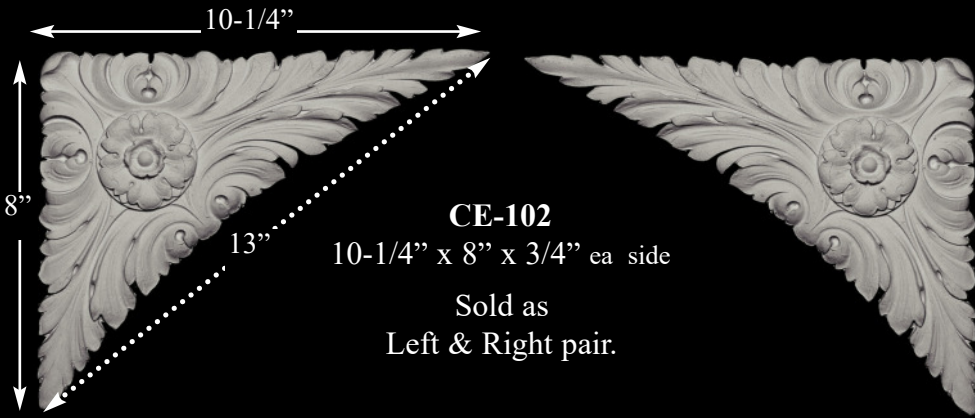

CE-102
 10-1/4" x 8" x 3/4" ea side
 Sold as
 Left & Right pair.



CE-105
 9-1/4" x 9-1/4" x 1"
 Designed to use with MLD-171

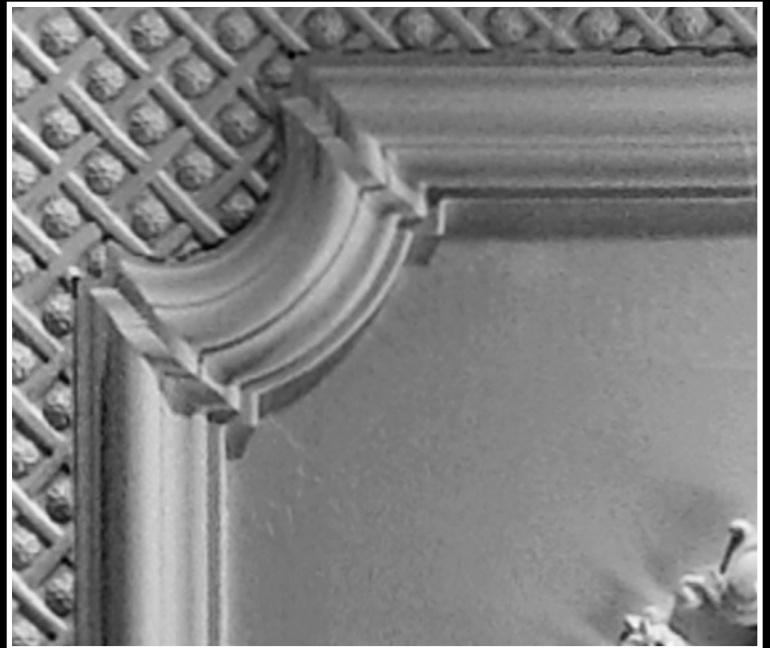

CORNER ELEMENTS

* All sizes are approx.- max W" x max H" x Thickness"

CORNER ELEMENTS



CE-108A

7" x 10" x 1"

See Corner Elements section for a wall panel design concept.



CE-108A-EXT

10" x 11" x 1"



CE-160A

7" x 10" x 1"



CE-160A-EXT

10" x 11" x 1"



Any 1" - 1-1/4" wide connection moulding will work with CE-108 and CE-160 series corner elements.

* Most popular connection mouldings for CE-108 and CE-160 series corner elements.



MLD-B-111B



MLD-137VSA



MLD-216A



MLD-111C



MLD-139C



MLD-254C



MLD-119CL



MLD-135C



MLD-201C



MLD-213C



CE-160A-EXT

CE-108A

MLD-B-111B

CORNER ELEMENTS



CE-108A

* All sizes are approx.- max W" x max H" x Thickness"

CORNER ELEMENTS



CORNER ELEMENTS

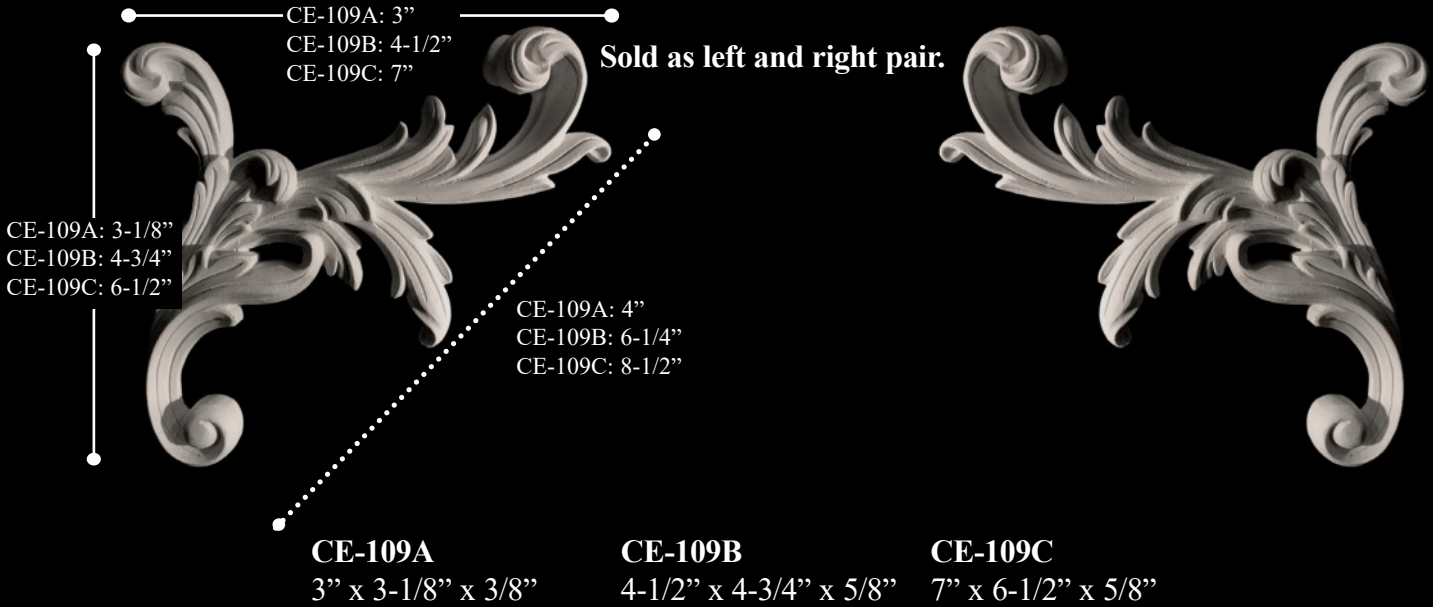

Any 1/2" - 5/8" wide connection moulding will work with CE-109A.

* Most popular designs for CE-109A.



Any 1/2" - 3/4" wide connection moulding will work with CE-109B.

* Most popular designs for CE-109B.

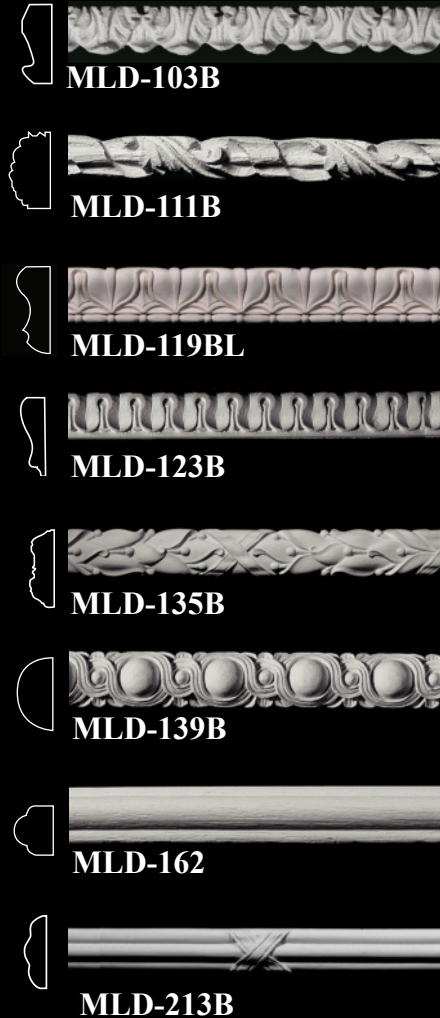

Any 3/4" - 1" wide connection moulding will work with CE-109C.

* Most popular designs for CE-109C.

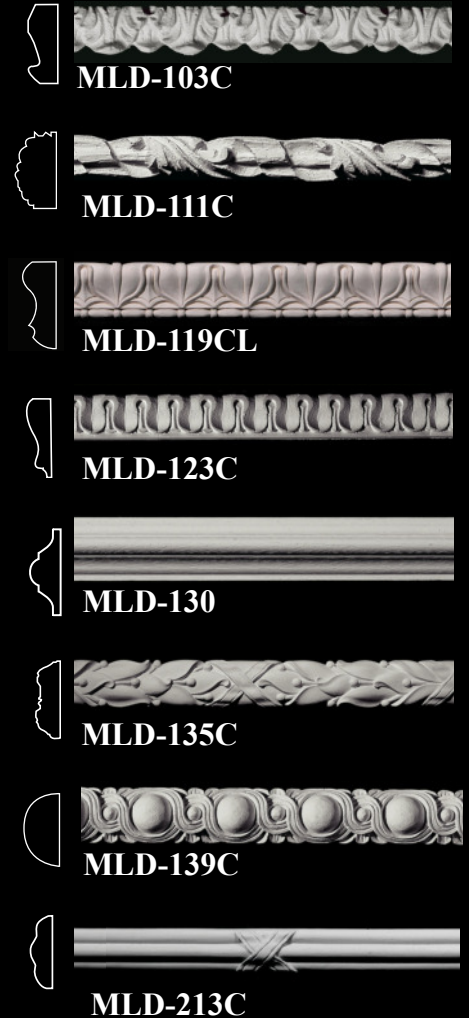

* All sizes are approx.- max W" x max H" x Thickness"

CORNER ELEMENTS

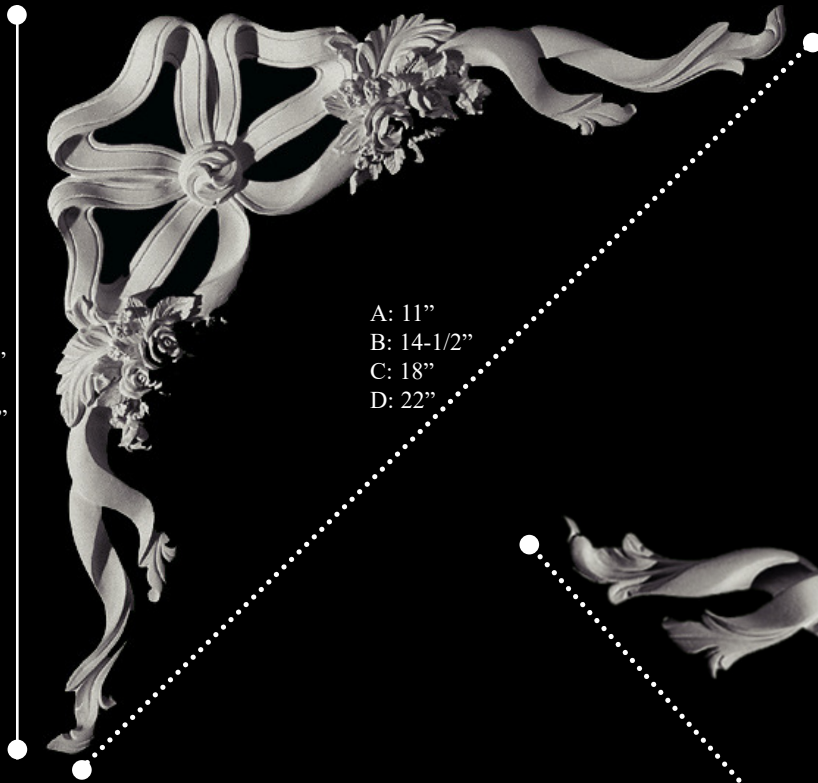

A: 8"
B: 10-1/4"
C: 13"
D: 15-1/2"

A: 11"
B: 14-1/2"
C: 18"
D: 22"

CE-110A
8" x 8" x 3/4"

CE-110B
10-1/4" x 10-1/4" x 1"

CE-110C
13" x 13" x 1"

CE-110D
15-1/2" x 15-1/2" x 1-1/4"

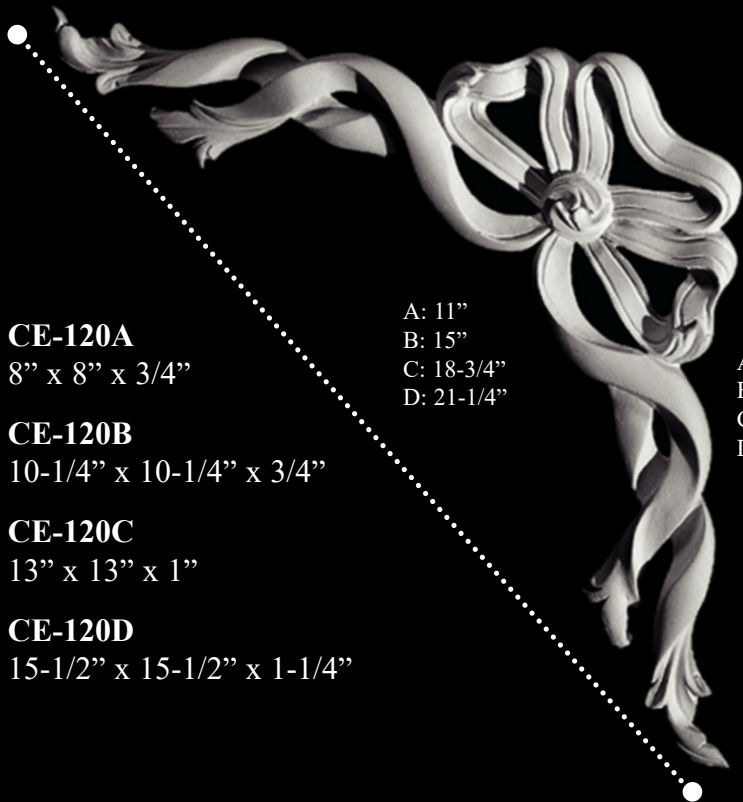

A: 11"
B: 15"
C: 18-3/4"
D: 21-1/4"

A: 8"
B: 10-1/4"
C: 13-1/2"
D: 15-1/2"

CE-120A
8" x 8" x 3/4"

CE-120B
10-1/4" x 10-1/4" x 3/4"

CE-120C
13" x 13" x 1"

CE-120D
15-1/2" x 15-1/2" x 1-1/4"

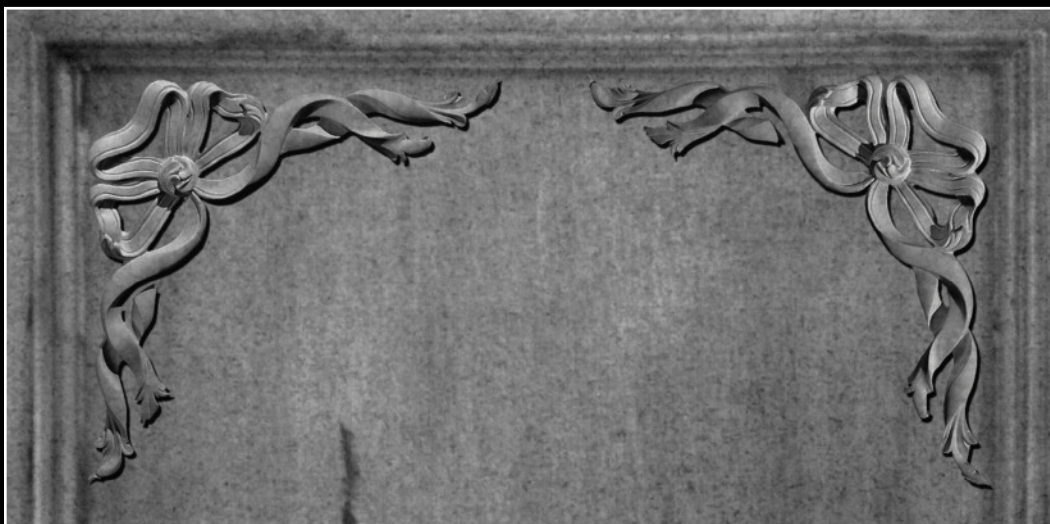

CORNER ELEMENTS

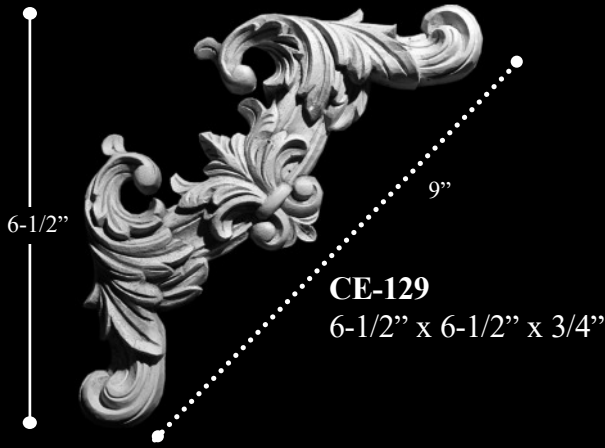

CE-129
6-1/2" x 6-1/2" x 3/4"

Any 3/4" - 1" wide connection moulding will work with CE-129. Check our website for more options.

* Most popular designs for CE-129.

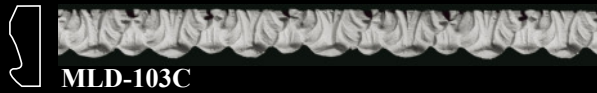

MLD-103C



MLD-B111B



MLD-116B



MLD-119CL



MLD-123C



MLD-212A



CE-133
11-1/4" x 11-1/4" x 1"

Any 1-1/2" - 2" wide connection moulding will work with CE-133. Check our website for more options.

* Most popular designs for CE-133.



MLD-120



MLD-139



MLD-211B



MLD-212D



MLD-214A

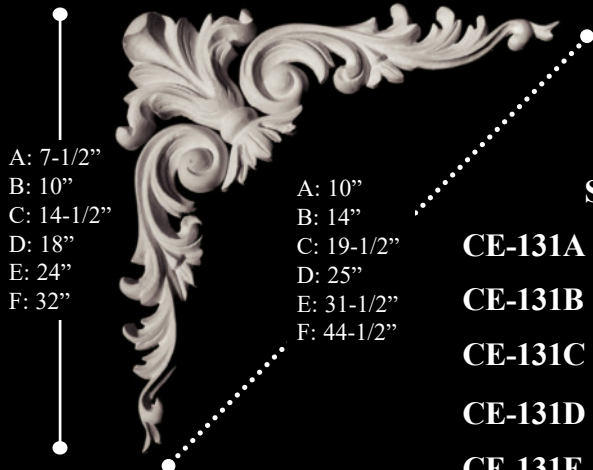

- A: 7-1/2"
- B: 10"
- C: 14-1/2"
- D: 18"
- E: 24"
- F: 32"

- A: 10"
- B: 14"
- C: 19-1/2"
- D: 25"
- E: 31-1/2"
- F: 44-1/2"

Sold As 3 Piece Set

- CE-131A** 7-1/2" x 7-1/2" x 3/4"
- CE-131B** 10" x 10" x 3/4"
- CE-131C** 14-1/2" x 14-1/2" x 3/4"
- CE-131D** 18" x 18" x 1"
- CE-131E** 24" x 24" x 1-1/4"
- CE-131F** 32" x 32" x 1-1/4"



CORNER ELEMENTS

* All sizes are approx.- max W" x max H" x Thickness"

CORNER ELEMENTS



CORNER ELEMENTS



CE-138A
 6-1/4" x 6-1/4" x 3/4"
 Designed to use MLD-216A

CE-138B
 7" x 7" x 3/4"
 Designed to use MLD-216B

CE-138C
 10" x 10" x 1"
 Designed to use MLD-216C

Corner Element
 End view

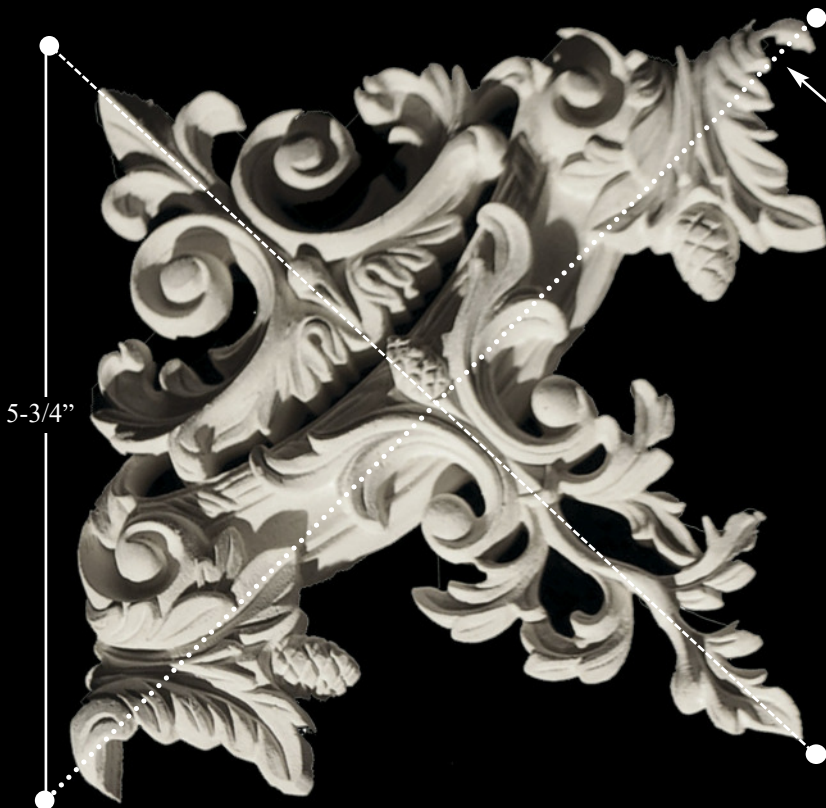
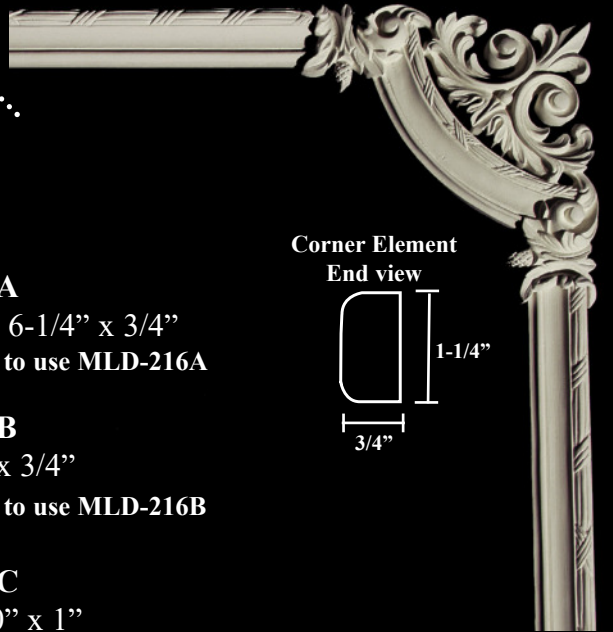
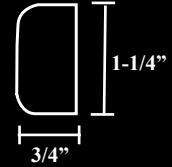

CE-138A-EXT
 5-3/4" x 5-3/4" x 3/4"
 Designed to use MLD-216A

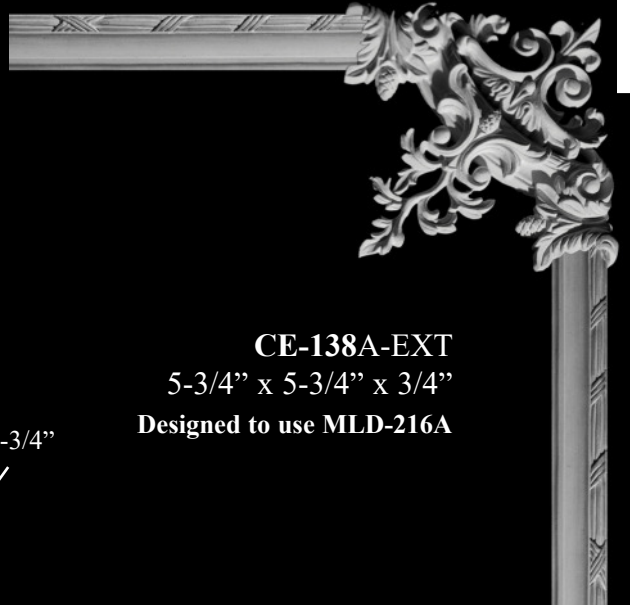

CORNER ELEMENTS

* All sizes are approx.- max W" x max H" x Thickness"

CORNER ELEMENTS

Connection Mouldings For: CE-136, 137A & B, 139, 140, 141

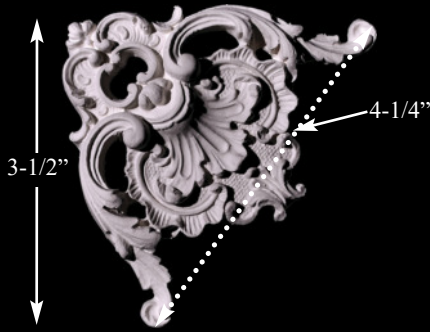

CE-136
3-1/2" x 3-1/2" x 1/2"

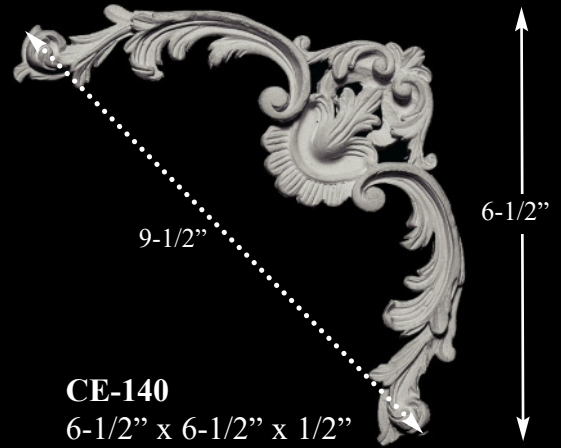

CE-140
6-1/2" x 6-1/2" x 1/2"

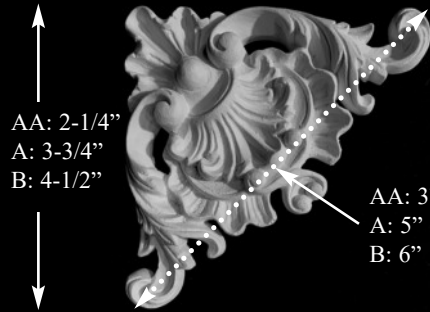

CE-137AA
2-1/4" x 2-1/4" x 3/8"

CE-137A
3-3/4" x 3-3/4" x 3/8"

CE-137B
4-1/2" x 4-1/2" x 3/4"

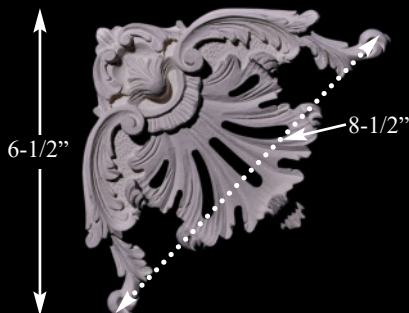

CE-139
6-1/2" x 6-1/2" x 3/4"



CORNER ELEMENTS

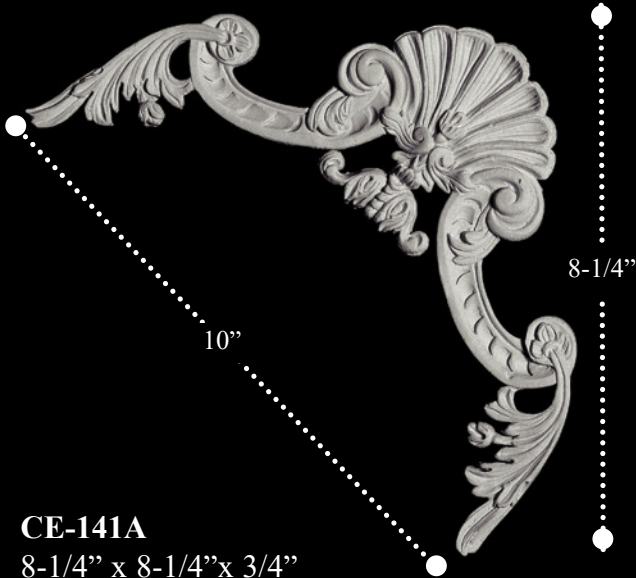

CE-141A
8-1/4" x 8-1/4" x 3/4"



Corner elements can also be used as a wall panel build-up

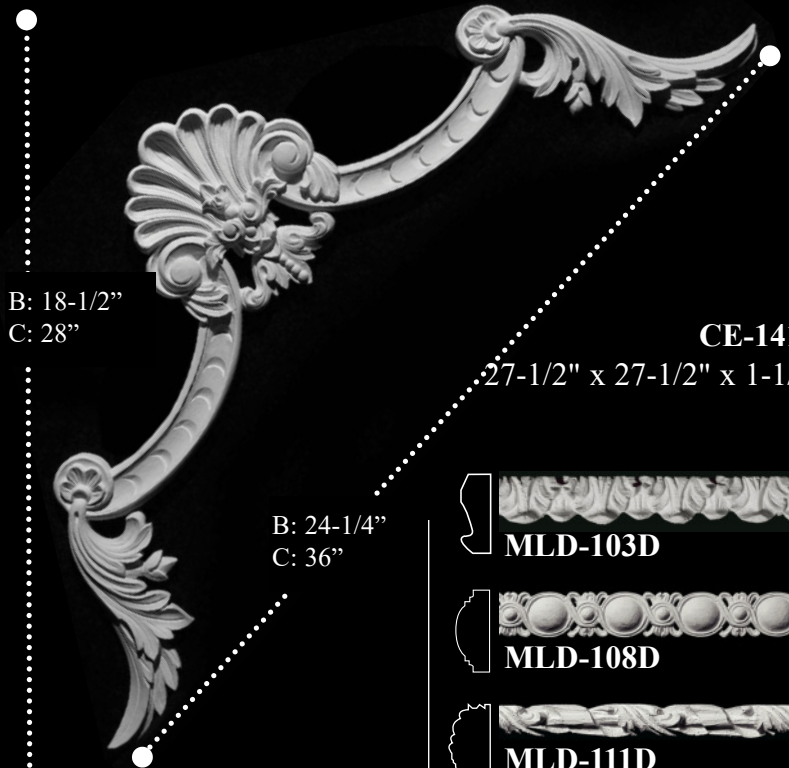

CE-141C

27-1/2" x 27-1/2" x 1-1/2"

B: 18-1/2"
C: 28"

B: 24-1/4"
C: 36"

CE-141B
18-1/2" x 18-1/2" x 1"

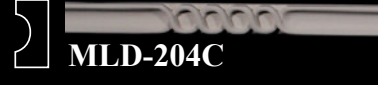

* All sizes are approx. - max W" x max H" x Thickness"

CORNER ELEMENTS

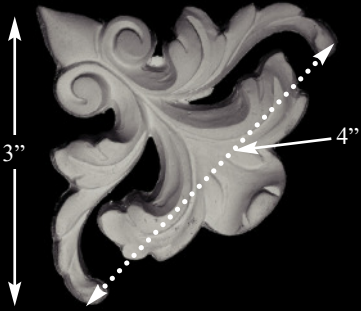

CE-132
3" x 3" x 1/2"

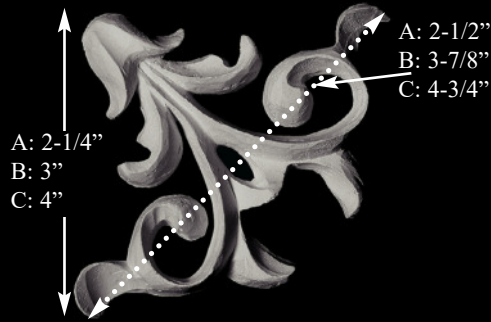

CE-134A 2" x 2" x 3/8"
CE-134B 3" x 3" x 1/2"
CE-134C 4" x 4" x 1/2"

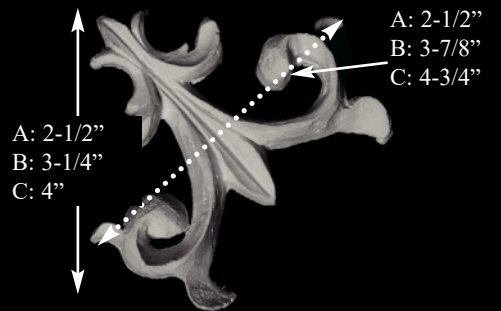

CE-135A 2-1/4" x 2-1/4" x 1/2"
CE-135B 3-1/4" x 3-1/4" x 1/2"
CE-135C 4" x 4" x 1/2"

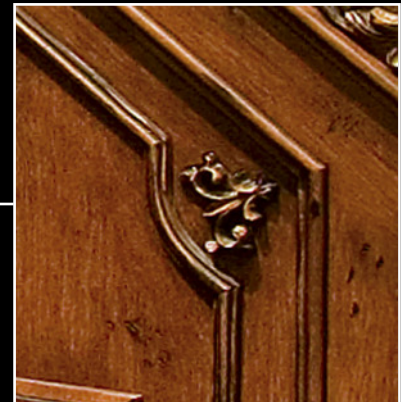

CORNER ELEMENTS

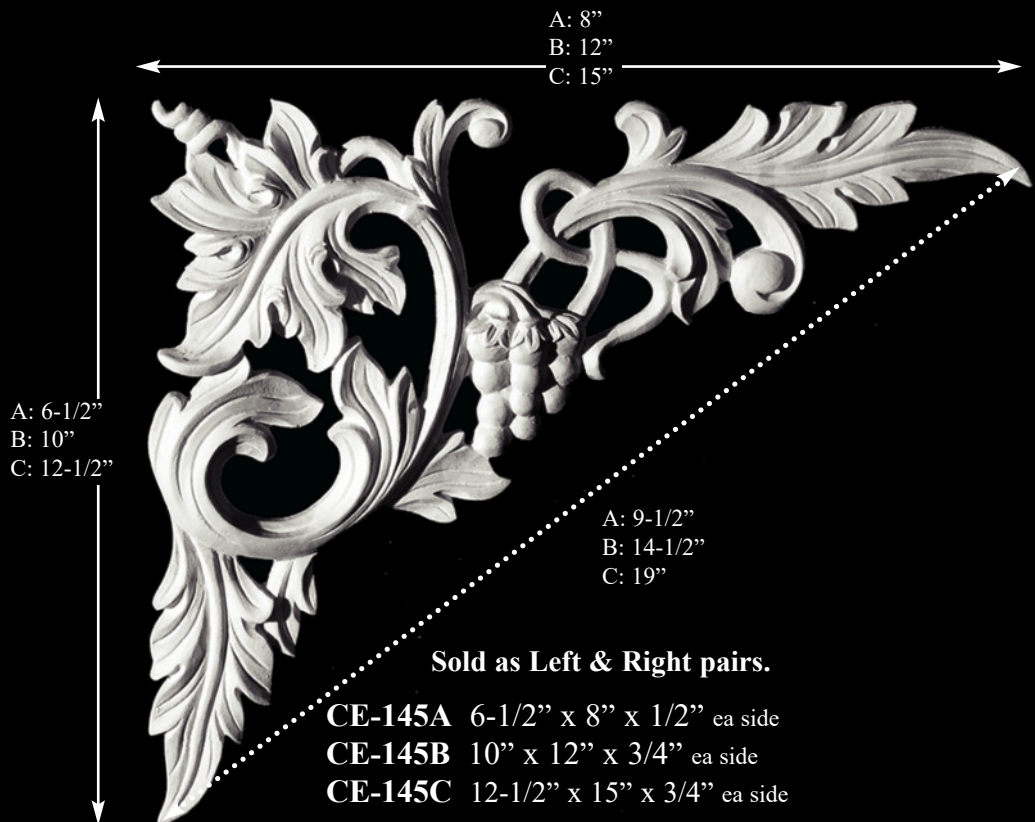
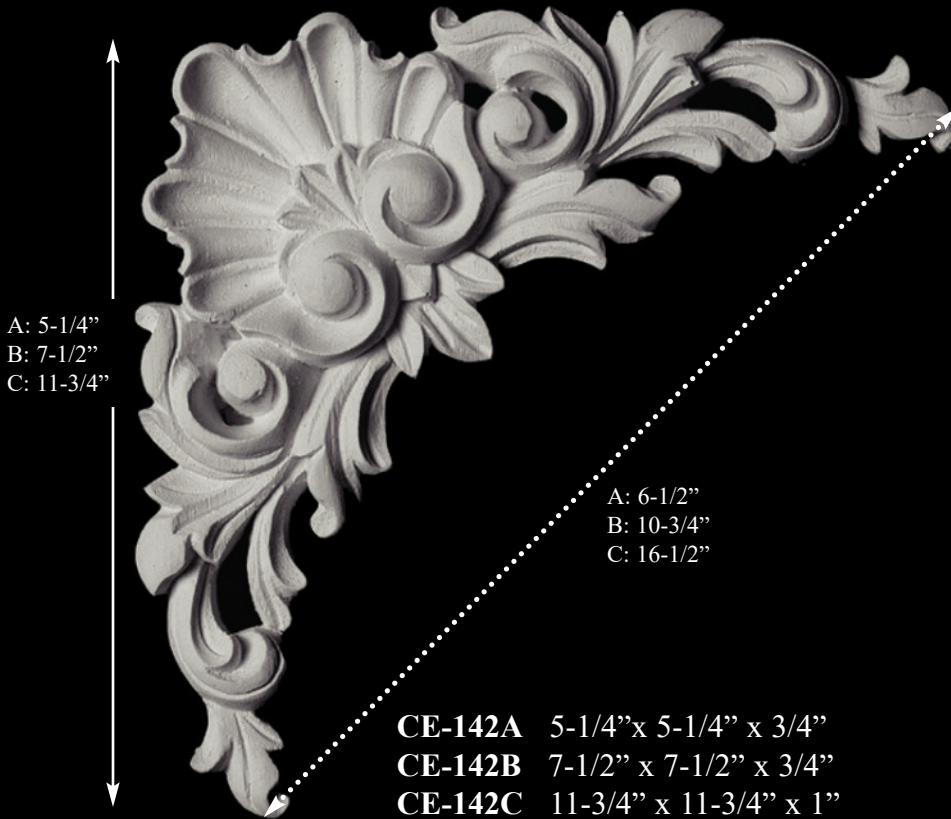

CORNER ELEMENTS

* All sizes are approx.- max W" x max H" x Thickness"

CORNER ELEMENTS

CE-151 Series Modular recessed corner panels for CURVED TOP cabinets.

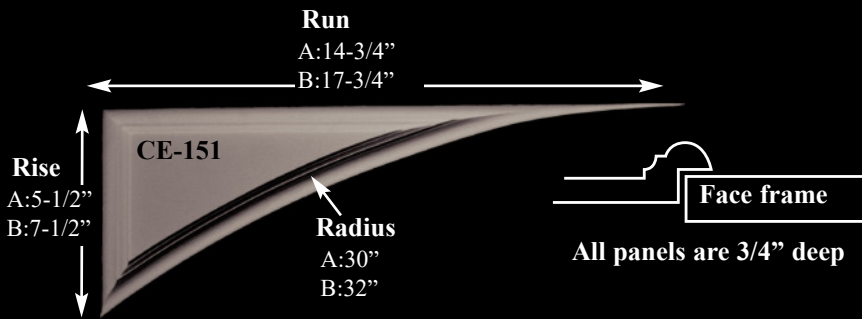

CE-151A \$109.95 (body only)
Rise: 5-1/2" Run: 14-3/4" Radius: 30"
For inside diameter cabinet openings between 30"-40" wide

CE-151B \$131.95 (body only)
Rise: 7-1/2" Run: 17-3/4" Radius: 32"
For inside diameter cabinet openings between 40"-48" wide

The CE-151 series inserts are offered in 7 Unique Designs, sold as left and right pair. All of the carved details simply drop inside the corner element body.

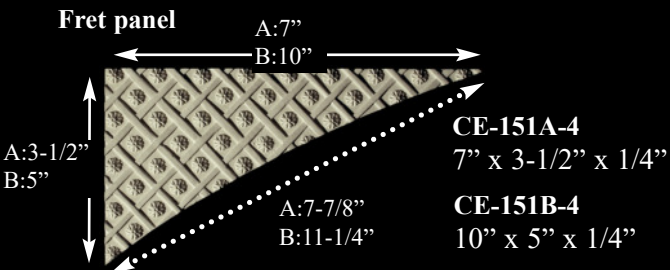
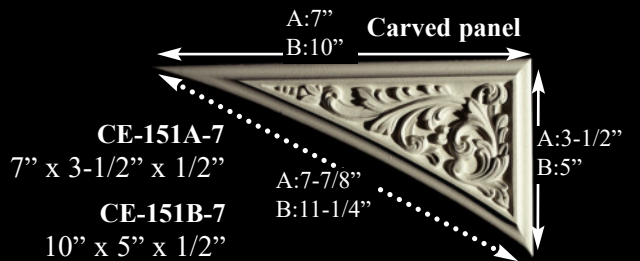
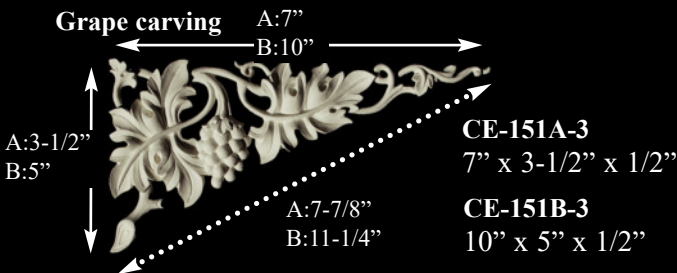
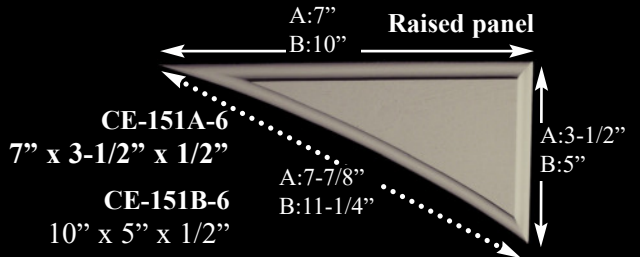
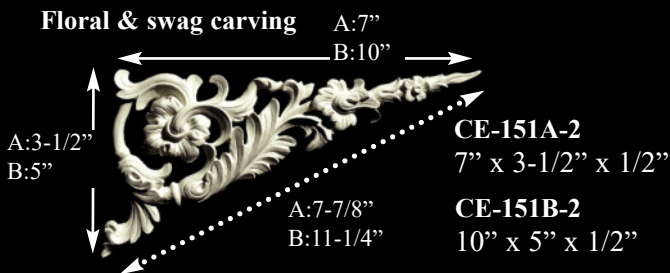
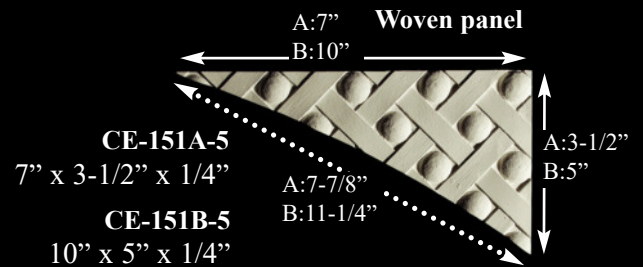
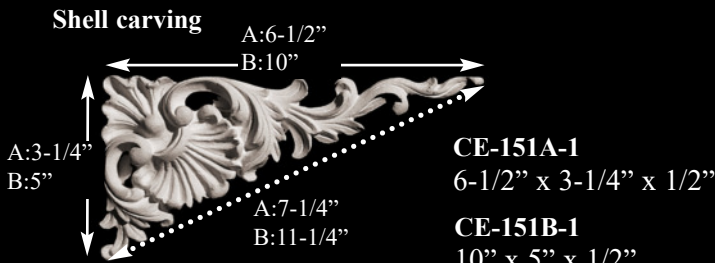

Pearlworks pre-engineered corner panels save hours of labor. Installation is as simple as cutting a hole and nailing the panels in place.

* All sizes are approx.- max W" x max H" x Thickness"

CORNER ELEMENTS

This series of corner elements was designed to easily add architectural embellishments to cabinets that use a curved top.

The CE-151 is shown with 7 Unique Designs:



CE-151A shown with CE-151A-1



Pearlworks is proud to be the first company to introduce a modular corner element for radius top cabinet face frames. Our new CE-151 series of corner elements offers 7 unique designs that fit small upper cabinets to larger units for entertainment centers.

All curved top face frames create dead corners that always look like they need some sort of detail. Pearlworks solution is a complete modular assembly which includes two corner elements along with the flexible moulding and keystone for the inner detail on your face frame.

CORNER ELEMENTS

CORNER ELEMENTS



Fixed Radius Corner Elements

Cutting Instructions



Set your mitre saw to 39° to make this cut.

*All precast radius corners are modified by the factory to make work. Some designs will require more blending at the inner sections due to design and profile variations.

All pre-cast radius corners come with factory suggested cut instructions as a starting point. Please note the degree number can and will vary depending on customer applications.

CORNER ELEMENTS

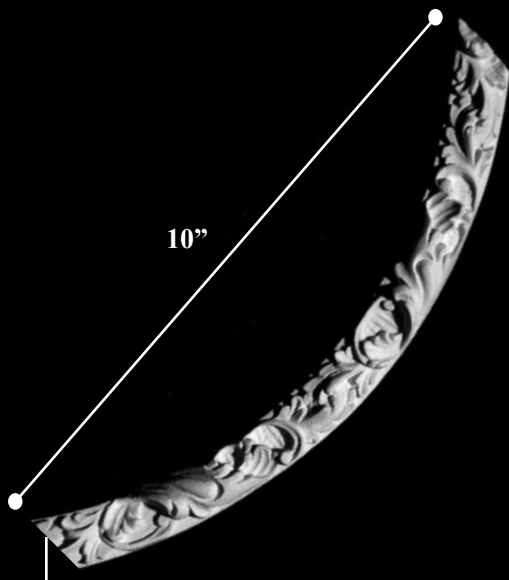

Precast radius corner elements require a specific cut angle. We use 43° for the connection moulding joint.

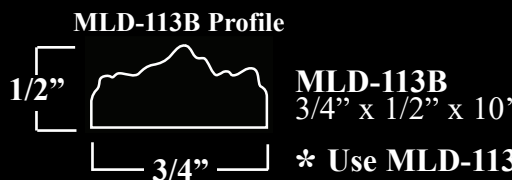

* Use MLD-113B for straights.

* All sizes are approx.- max W" x Thickness" x Length"

CORNER ELEMENTS

Corner element is designed for FF-101 Face Frame.

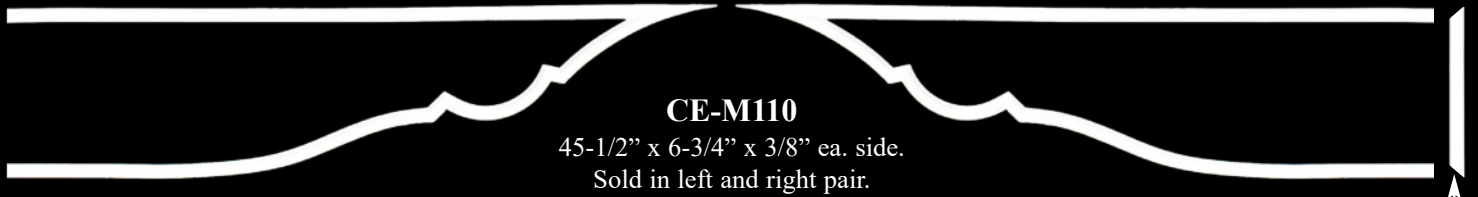

CE-M110

45-1/2" x 6-3/4" x 3/8" ea. side.

Sold in left and right pair.

* CE-M110 All curves pre-cast.
All you need to do is cut for ends.

MLD-110 Profile * Use MLD-110 for straights.

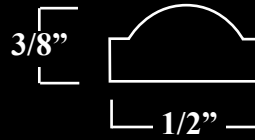

MLD-110

1/2" x 3/8" x 10'



CORNER ELEMENTS



CORNER ELEMENTS

* All sizes are approx.- max W” x Thickness” x Length”

CORNER ELEMENTS

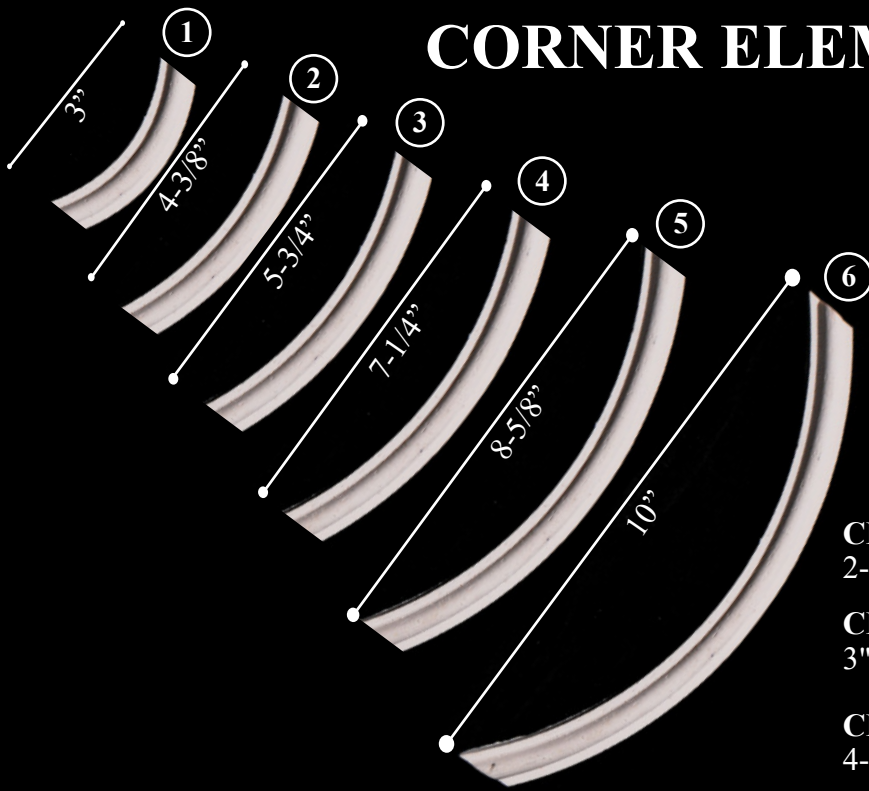

CE-200A
2-1/4" x 2-1/4" x 1/2"

CE-200DL
5" x 5" x 3/4"

CE-200B
3" x 3" x 1/2"

CE-200DD
6" x 6" x 1"

CE-200C
4-1/2" x 4-1/2" x 3/4"

CE-200EL
6-3/4" x 6-3/4" x 3/4"

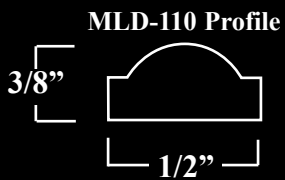

MLD-110
1/2" x 3/8" x 10'

* Use MLD-110 for straights.

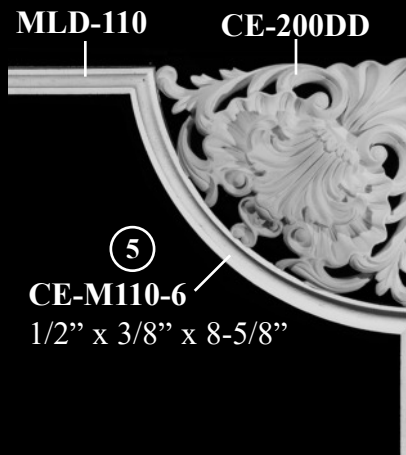
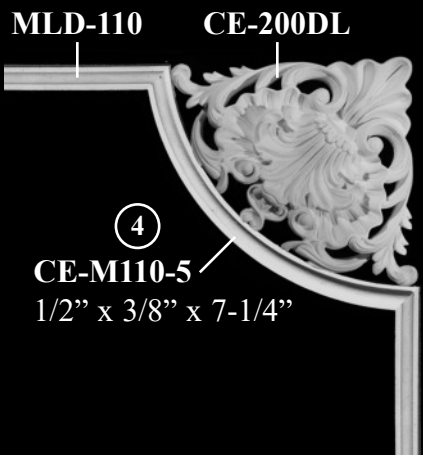
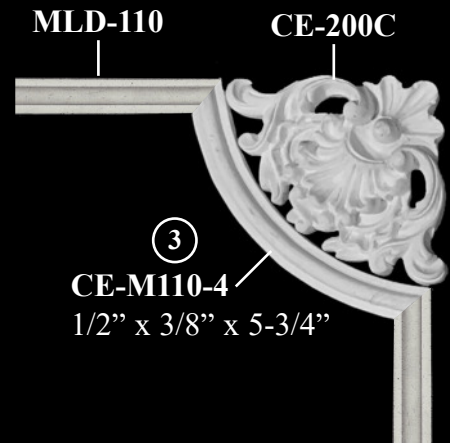
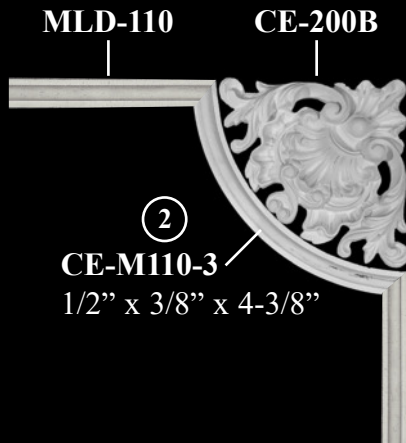
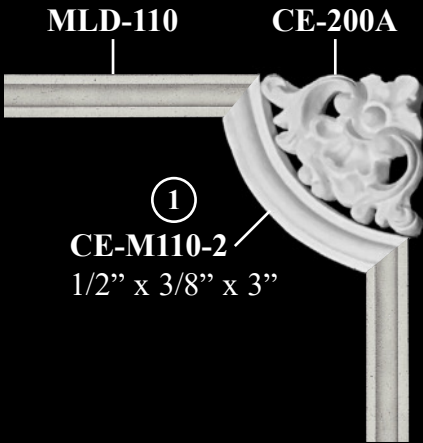

CORNER ELEMENTS

CE-M120 Series (3 sizes available)

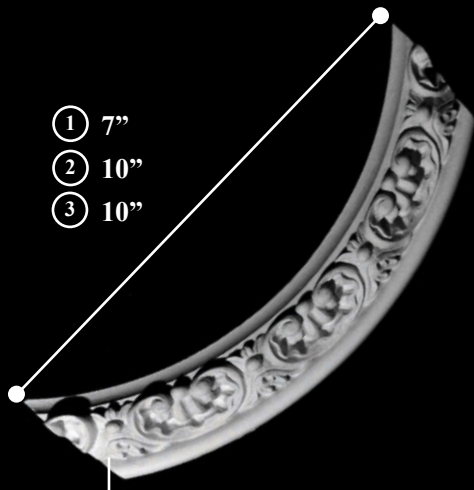

Precast radius corner elements require a specific cut angle. We use 39° for the connection moulding joint.



CE-200D
5" x 5" x 3/4"

CE-200E
6-3/4" x 6-3/4" x 1-1/4"

* Uses MLD-120A or MLD-120B for straights.

MLD-120A Profile



MLD-120A
2" x 1" x 10"

MLD-120B Profile



MLD-120B
3" x 1-1/4" x 5"



①
CE-M120A-5
2" x 1" x 7"



②
CE-M120A-7
2" x 1" x 10"



③
CE-M120B-7
3" x 1-1/4" x 10"

CE-M123VS-7

Part of the Versailles Collection

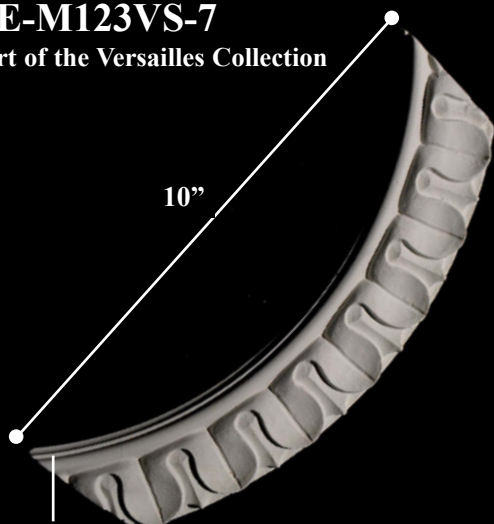

Precast radius corner elements require a specific cut angle. We use 41° for the connection moulding joint.



CE-M123VS-7
2" x 1/2" x 10"



MLD-123VS Profile **MLD-123VS**
2" x 1/2" x 10"

* Use MLD-123VS for straights.

* All sizes are approx.- max W" x Thickness" x Length"

CORNER ELEMENTS

CORNER ELEMENTS

CE-M160 Series

(4 sizes available)

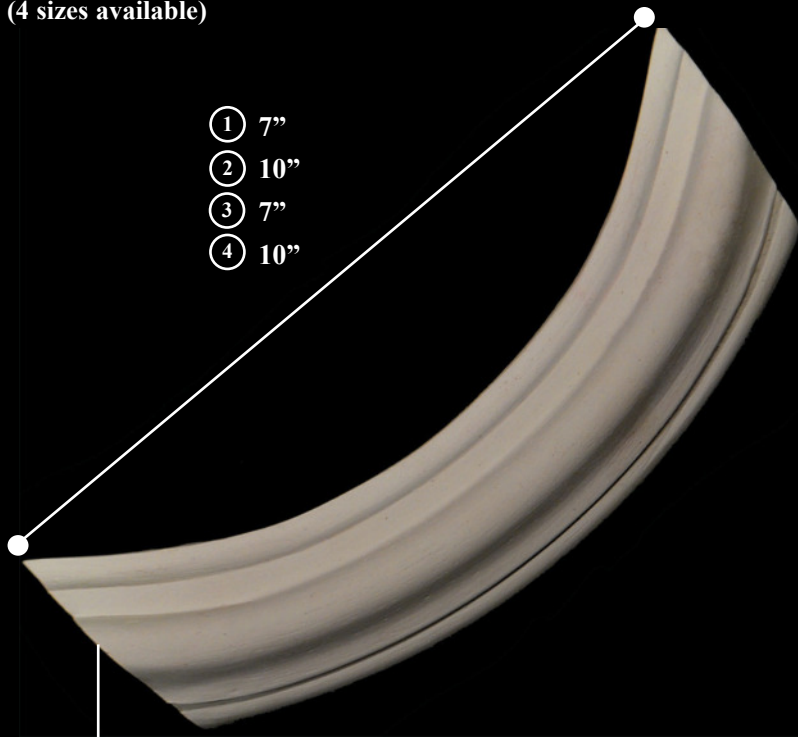

Precast radius corner elements require a specific cut angle. We use 40° for the connection moulding joint.



CE-M160A-5
1-1/2" x 3/4" x 7"



CE-M160A-7
1-1/2" x 3/4" x 10"



CE-M160B-5
2-1/4" x 1-1/4" x 7"



CE-M160B-7
2-1/4" x 1-1/4" x 10"

MLD-160A Profile



MLD-160A
1-1/2" x 3/4" x 10'

MLD-160B Profile



MLD-160B
2-1/4" x 1-1/8" x 10'

* MLD-160A or MLD-160B are used for straights.



CE-200D
5" x 5" x 3/4"

CE-200E
6-3/4" x 6-3/4" x 1-1/4"

CORNER ELEMENTS

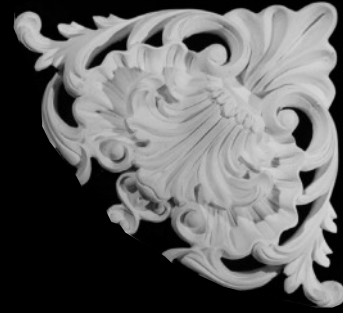
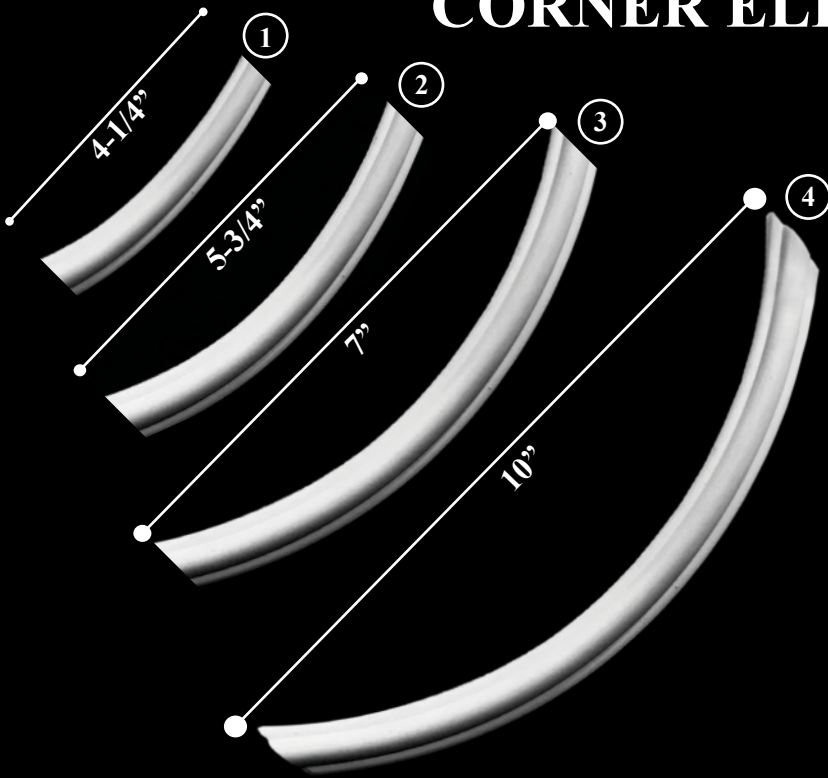

CE-200B
3" x 3" x 1/2"

CE-200DL
5" x 5" x 3/4"

CE-200C
4-1/2" x 4-1/2" x 3/4"

CE-200EL
6-3/4" x 6-3/4" x 3/4"

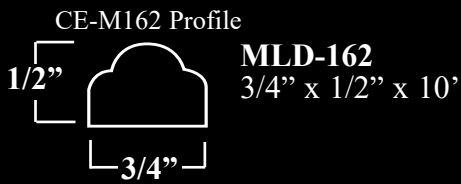

*Use MLD-162 for straights.

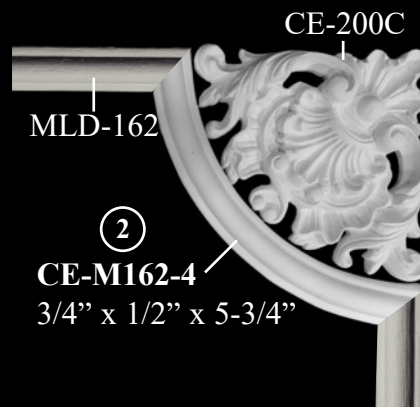
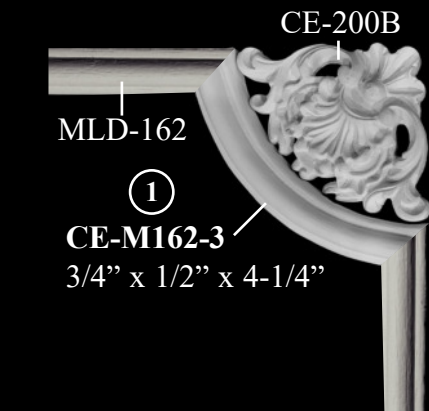

* All sizes are approx.- max W" x Thickness" x Length"

CORNER ELEMENTS

CORNER ELEMENTS

CE-M164 Series

(3 sizes available)

- ① 6-1/2"
- ② 13"
- ③ 15"

Precast radius corner elements require a specific cut angle. We use 59° (CE-M164A) 25° (CE-M164B and CE-M164C) for the connection moulding joint.

① **CE-M164AL**
1-3/8" x 5/8" x 6-1/2"

② **CE-M164BL**
1-3/8" x 5/8" x 13"

③ **CE-M164CL**
1-3/8" x 5/8" x 15"



RING-164AL

6-1/2" O.D x 3-3/4" I.D x 5/8" thick

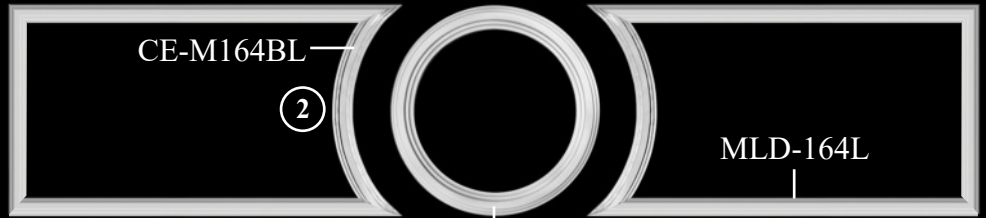

RING-164BL

13" O.D x 10" I.D x 5/8" thick



RING-164CL

15" O.D x 12-1/4" I.D x 5/8" thick

MLD-164L Profile

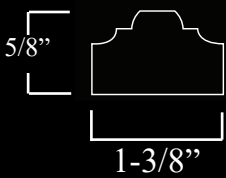

MLD-164L
1-3/8" x 5/8" x 10"

* Use MLD-164L for straights.

CE-M165 Series

(2 sizes available)

- ① 7"
- ② 10"

Precast radius corner elements require a specific cut angle. We use 40° for the connection moulding joint.

CE-200D

5" x 5" x 3/4"

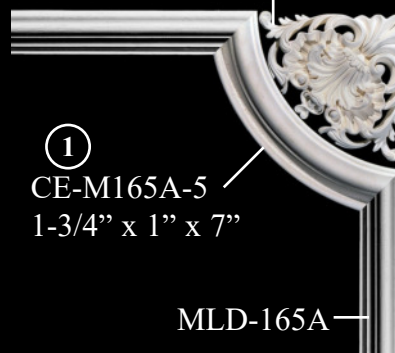

① **CE-M165A-5**
1-3/4" x 1" x 7"

MLD-165A

CE-200E

6-3/4" x 6-3/4" x 1-1/4"



② **CE-M165A-7**
1-3/4" x 1" x 10"

MLD-165A

MLD-165A Profile



MLD-165A
1-3/4" x 1" x 10"

* Use MLD-165A for straights.

CORNER ELEMENTS

CE-M171-OG Series

(2 sizes available)

① 11-1/4"

② 14"

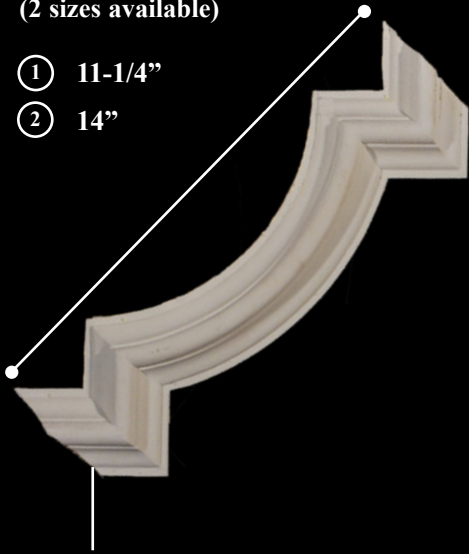

MLD-171F

CE-200-OG-5

MLD-171F

CE-200-OG-7

①
CE-M171-OG-5
2" x 11-1/4" x 3/4"

②
CE-M171-OG-7
2" x 14" x 3/4"

Precast radius corner elements require a specific cut angle. We use 45° for the connection moulding joint.

MLD-171 Profile



MLD-171F
2" x 1" x 10'

* Use MLD-171F for straights



CE-200-OG-5
7-3/4" x 10-3/4" x 1-1/4"

CE-200-OG-7
9-3/4" x 13-3/4" x 1-1/2"

CE-M171 Series

(2 sizes available)

① 7"

② 10"



CE-201A

CE-201B

①
CE-M171-5
2" x 7" x 1"

②
CE-M171-7
2" x 10" x 1"

MLD-171F

MLD-171F

Precast radius corner elements require a specific cut angle. We use 40° for the connection moulding joint.

MLD-171 Profile

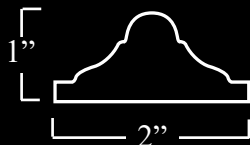

MLD-171F
2" x 1" x 10'

* Use MLD-171F for straights



CE-201A
17-1/4" x 17-1/4" x 1-1/8"
3-Piece Set

CE-201B
21" x 21" x 1-1/4"
3-Piece Set

* All sizes are approx.- max W" x Thickness" x Length"

CORNER ELEMENTS

Panel Moulding Corner Element

CE-M173 Series

(2 sizes available)

- ① 7"
- ② 10"

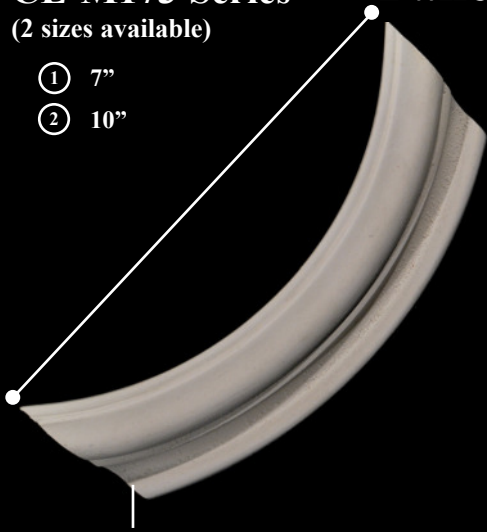

Precast radius corner elements require a specific cut angle. We use 39° for the connection moulding joint.

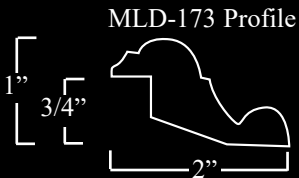

MLD-173
2" x 1" x 10'

* Use MLD-173 for straights.



CE-200D
5" x 5" x 3/4"

CE-200E
6-3/4" x 6-3/4" x 1-1/4"

Panel Moulding Corner Element

CE-M174 Series

(2 sizes available)

- ① 7"
- ② 10"

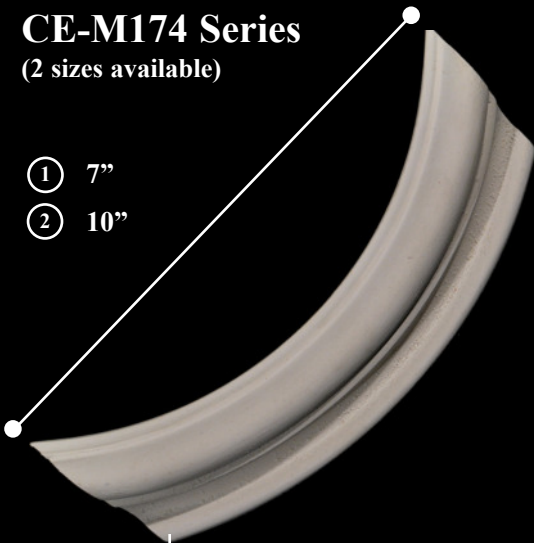

Precast radius corner elements require a specific cut angle. We use 39° for the connection moulding joint.

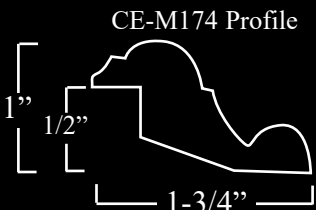

MLD-174
1-1/2" x 1" x 10'

* Use MLD-174 for straights.

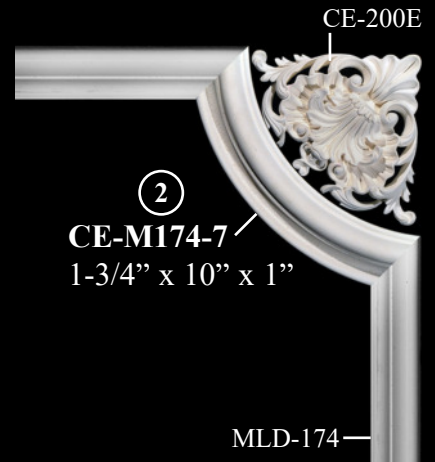

CE-200D
5" x 5" x 3/4"

CE-200E
6-3/4" x 6-3/4" x 1-1/4"

CE-M180A-OG Series

(2 sizes available)

- ① 11-1/4"
- ② 14"

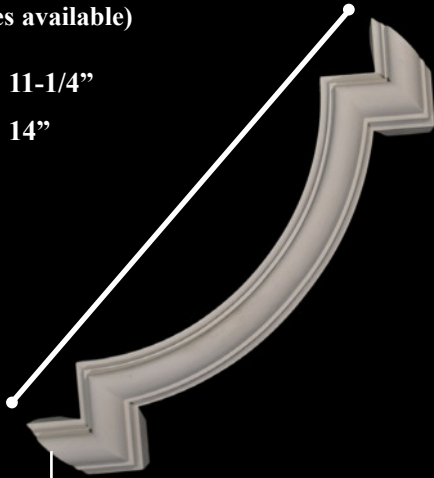

Precast radius corner elements require a specific cut angle. We use 45° for the connection moulding joint.

MLD-180A Profile

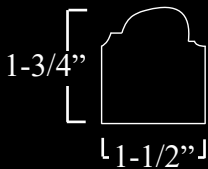

MLD-180AF
1-1/2" x 1-3/4" x 10'

* Use MLD-180AF for straights.

CORNER ELEMENTS

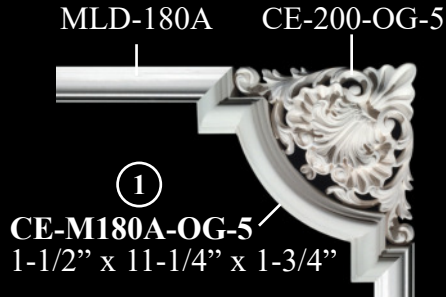

CE-200-OG-5
7-3/4" x 10-3/4" x 1-1/4"

CE-200-OG-7
9-3/4" x 13-3/4" x 1-1/2"

CE-M180A Series

(2 sizes available)

- ① 7"
- ② 10"



Precast radius corner elements require a specific cut angle. We use 39° for the connection moulding joint.

MLD-180A Profile



MLD-180AF
1-1/2" x 1-3/4" x 10'

* Use MLD-180AF for straights.

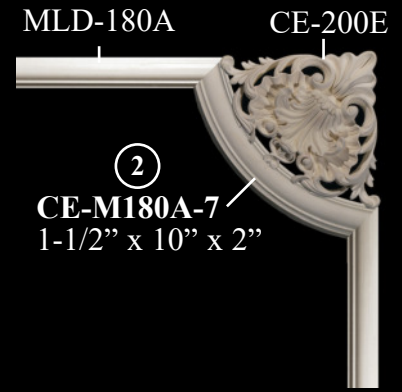
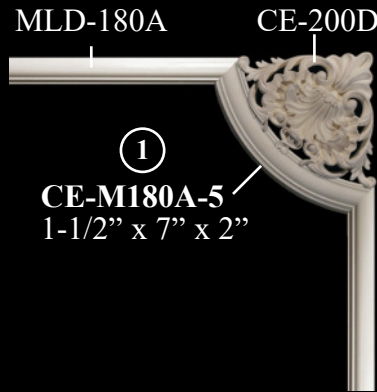

CE-200D
5" x 5" x 3/4"

CE-200E
6-3/4" x 6-3/4" x 1-1/4"

CORNER ELEMENTS

* All sizes are approx.- max W" x Thickness" x Length"

CORNER ELEMENTS

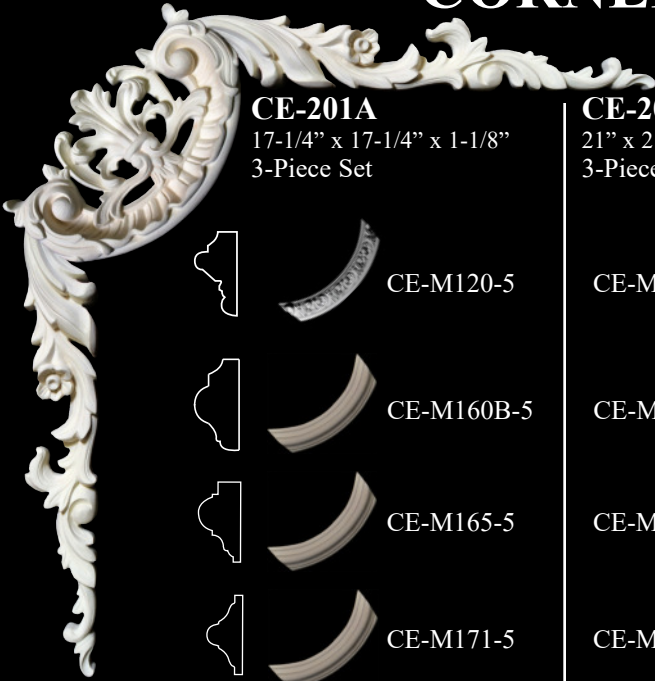

CE-201A
17-1/4" x 17-1/4" x 1-1/8"
3-Piece Set

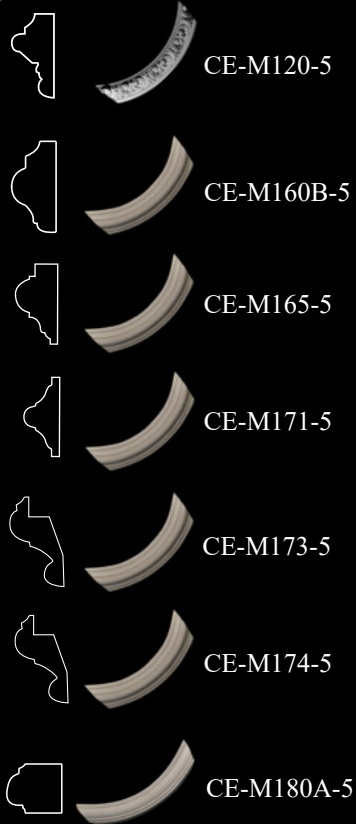

CE-201B
21" x 21" x 1-1/4"
3-Piece Set

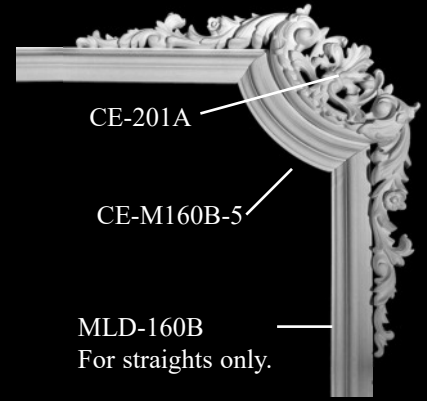
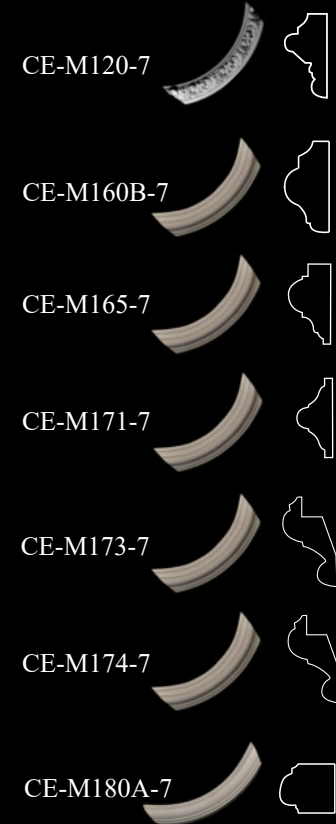

CE-201A
CE-M160B-5
MLD-160B
For straights only.

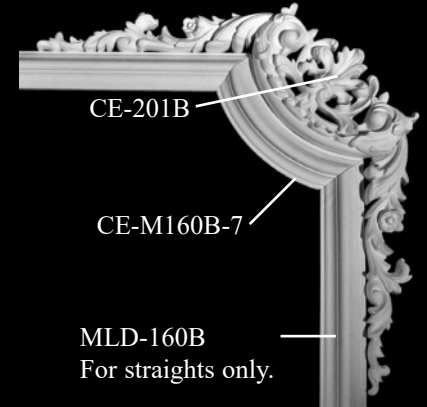

CE-201B
CE-M160B-7
MLD-160B
For straights only.

CE-200A 2"
CE-200B 3"
CE-200C 4-1/2"
CE-200D 5"

CE-200DD 6"
CE-200E 6-3/4"
CE-200DL 5"
CE-200EL 6-3/4"

CE-200A
2" x 2" x 1/2"
CE-200B
3" x 3" x 1/2"

CE-200DL
(Low Profile)
5" x 5" x 3/4"

CE-200EL
(Low Profile)
6-3/4" x 6-3/4" x 3/4"

CE-200C
4-1/2" x 4-1/2" x 3/4"

CE-200D
5" x 5" x 1"

CE-200DD
6" x 6" x 1"

CE-200E
6-3/4" x 6-3/4" x 1-1/4"

CE-200A 2"
CE-200B 3"
CE-200C 4-1/2"
CE-200D 5"
CE-200DD 6"
CE-200E 6-3/4"
CE-200DL 5"
CE-200EL 6-3/4"

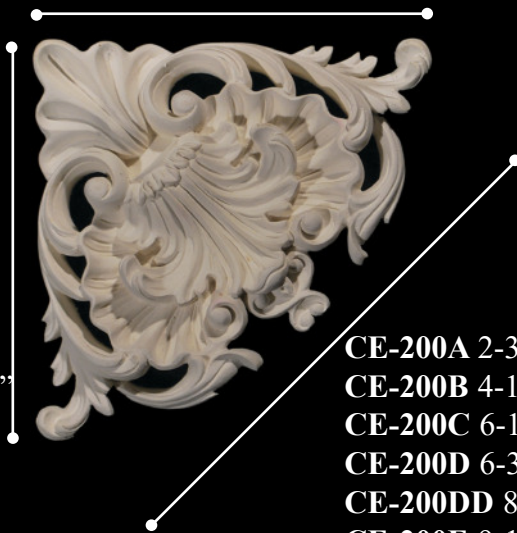

CE-200A 2-3/4"
CE-200B 4-1/4"
CE-200C 6-1/8"
CE-200D 6-3/4"
CE-200DD 8-1/4"
CE-200E 9-1/2"
CE-200DL 6-3/4"
CE-200E 9-1/2"

CORNER ELEMENTS

CE-200-OG-5
7-3/4"

CE-200-OG-7
9-3/4"

CE-200-OG-5
7-3/4"

CE-200-OG-7
9-3/4"

CE-200-OG-5
10-1/2"

CE-200-OG-7
13-1/2"

CE-200-OG-5

CE-M171-OG-5

MLD-171

CORNER ELEMENTS

The OG design of the CE-200 was designed with extended carved detail for proper fit to our CE-MLD-171-OG

CE-200-OG-5
7-3/4" H x 10-3/4" W x 1-1/4" Thick

CE-200-OG-7
9-3/4" H x 13-3/4" W x 1-1/2" Thick

* All sizes are approx.- max W" x Thickness" x Length"

CORNER ELEMENTS

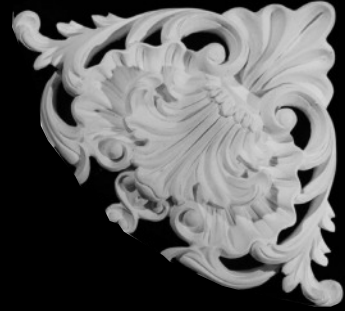
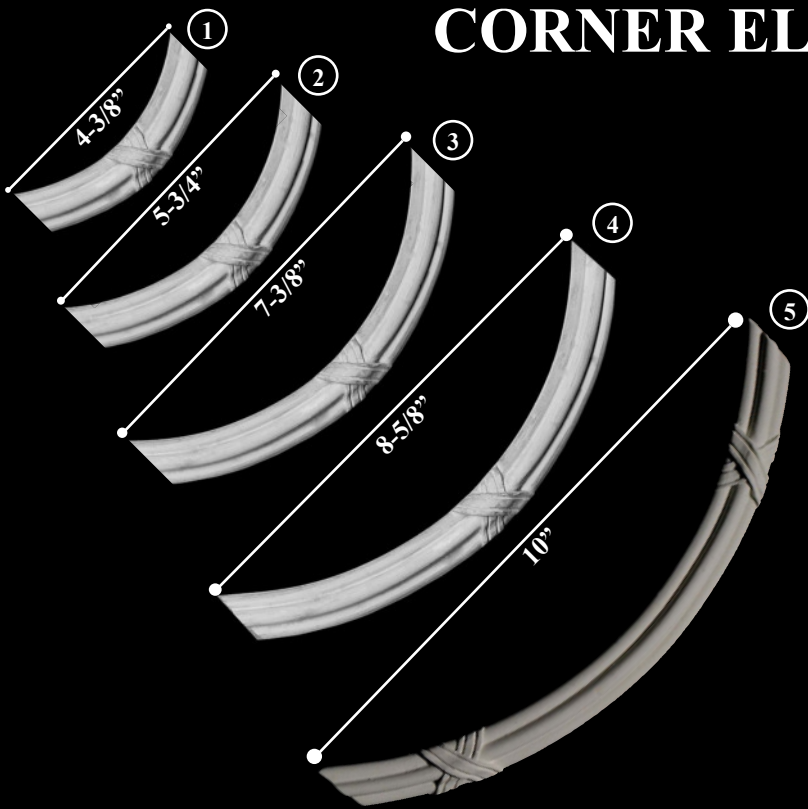

CE-200B
3" x 3" x 1/2"

CE-200DD
6" x 6" x 1"

CE-200C
4-1/2" x 4-1/2" x 3/4"

CE-200EL
6-3/4" x 6-3/4" x 3/4"

CE-200DL
5" x 5" x 3/4"

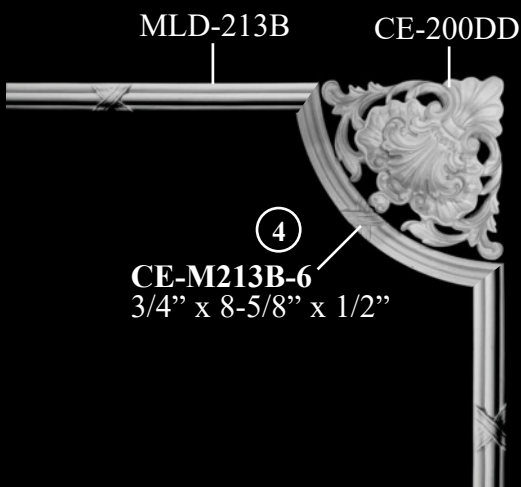
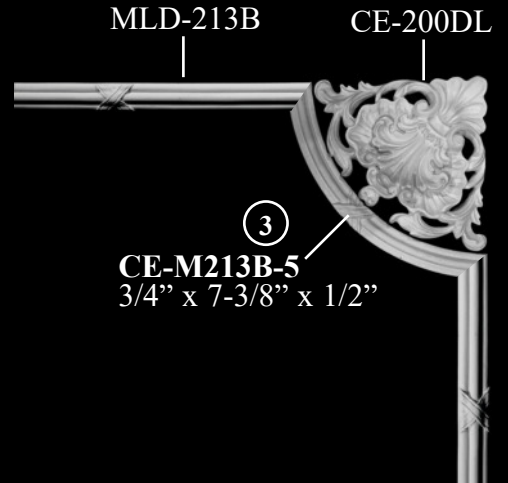
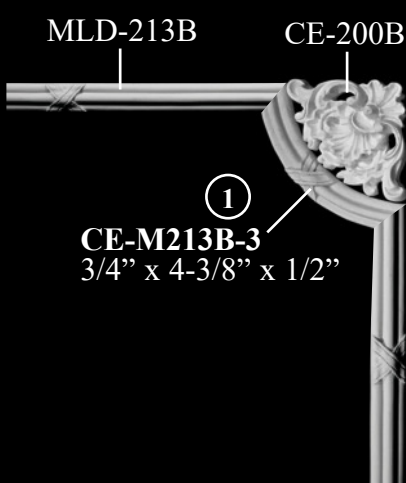

* Use MLD-213B for straights.

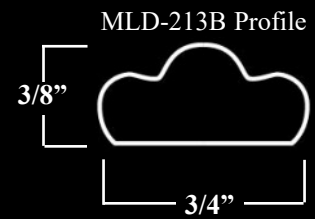

MLD-213B
3/4" x 3/8" x 10'

CORNER ELEMENTS

CE-M216 Series

(6 sizes available)

- ① 4-3/8"
- ② 7"
- ③ 10"
- ④ 7"
- ⑤ 10"
- ⑥ 10"

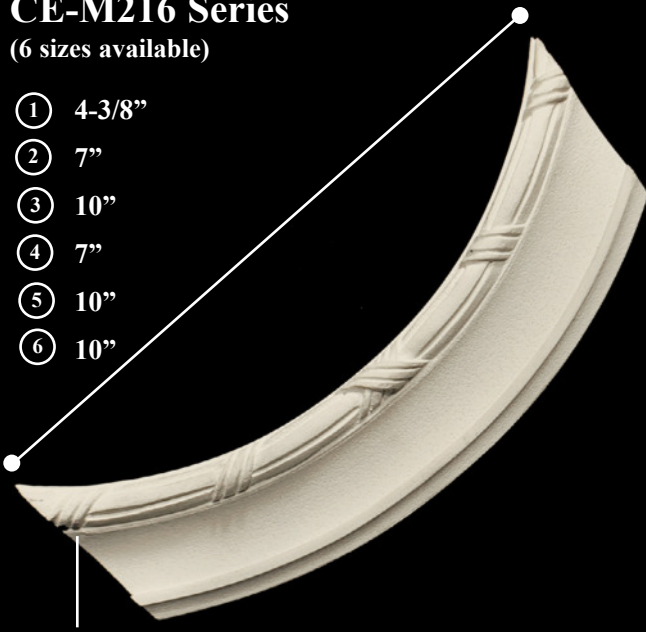

Precast radius corner elements require a specific cut angle. We use 40° for the connection moulding joint.

* MLD-216A, MLD-216B or MLD-216C are used for straights.

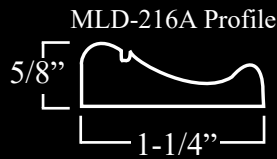

MLD-216A
1-1/4" x 5/8" x 10'

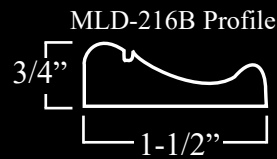

MLD-216B
1-1/2" x 3/4" x 10'

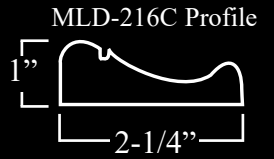

MLD-216C
2-1/4" x 1" x 10'



CE-200B
3" x 3" x 1/2"

CE-200D
5" x 5" x 3/4"

CE-200E
6-3/4" x 6-3/4" x 1-1/4"

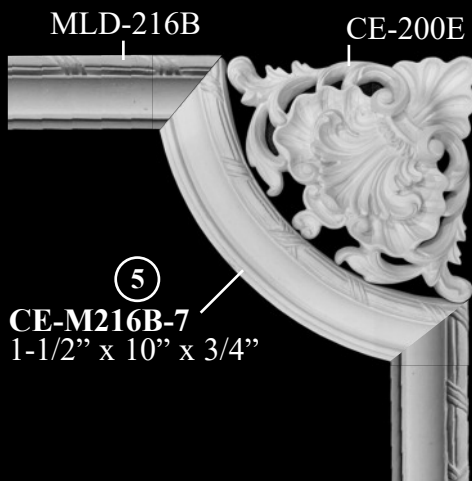
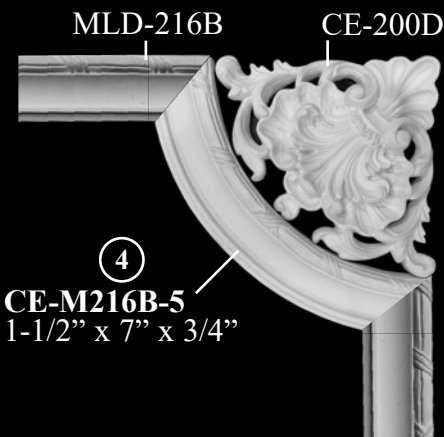
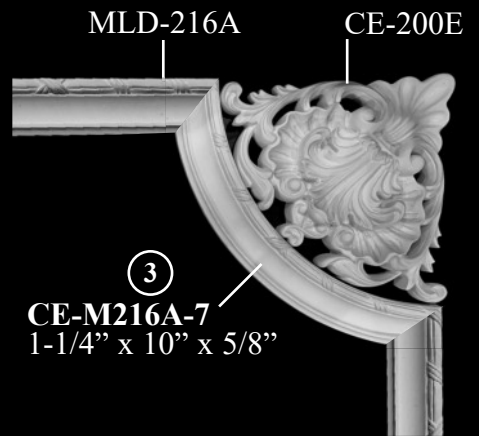
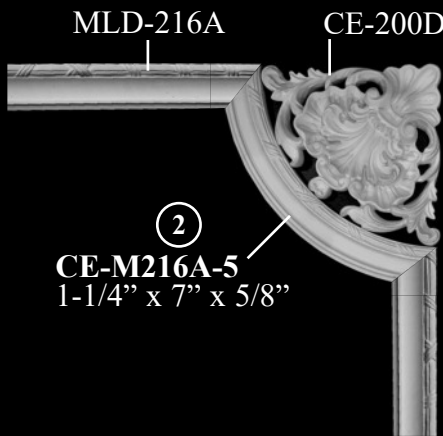
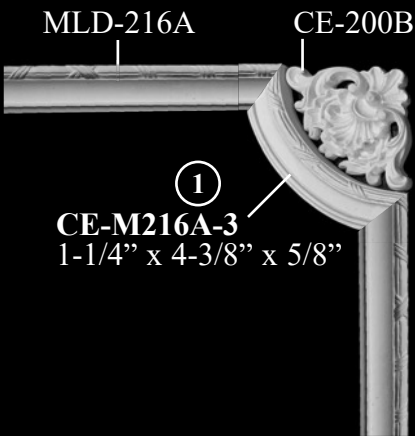

CORNER ELEMENTS

CORNER ELEMENTS

CE-216A-HR
8-1/4" x 5" x 5/8"

CE-216B-HR
11" x 7" x 3/4"

CE-216A-HR: 5"
CE-216B-HR: 7"

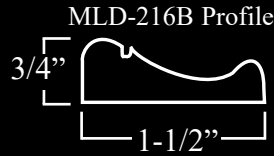
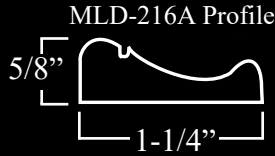
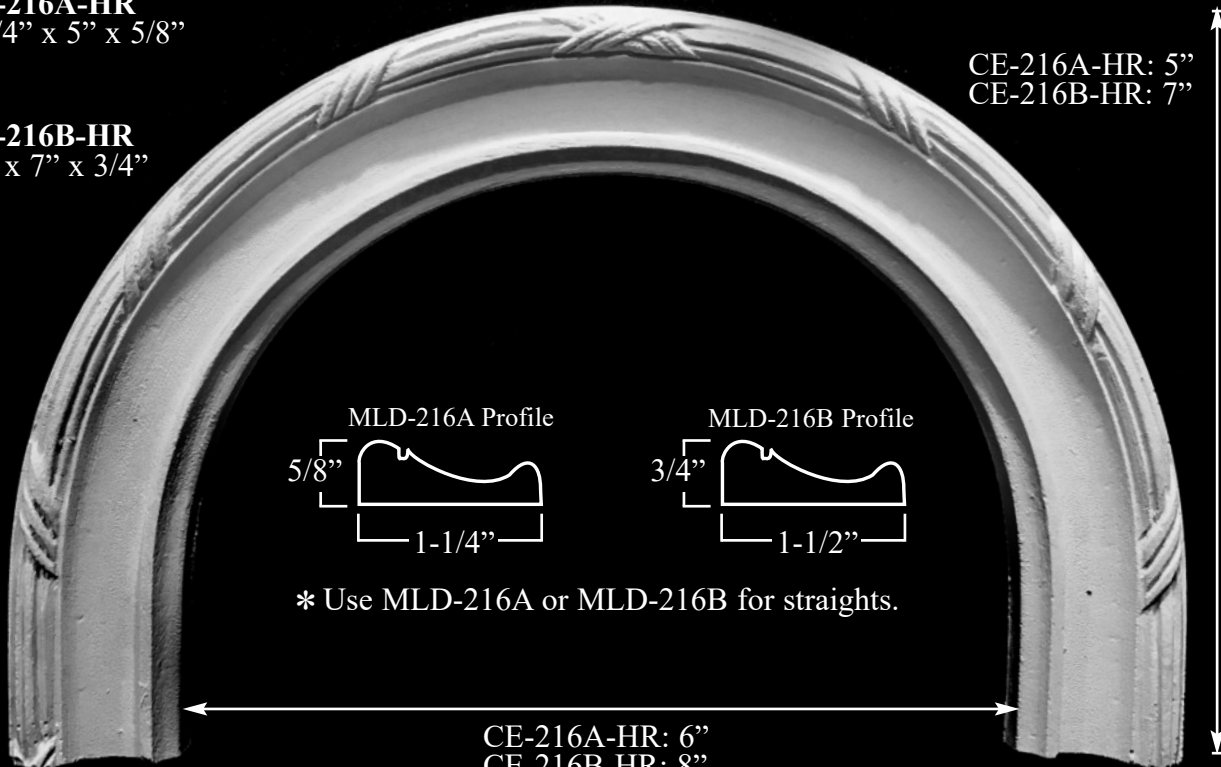

* Use MLD-216A or MLD-216B for straights.

CE-216A-HR: 1-1/4"
CE-216B-HR: 1-1/2"

CE-216A-HR: 1-1/4"
CE-216B-HR: 1-1/2"

CE-216A-HR: 6"
CE-216B-HR: 8"

CE-216A-HR: 8-1/4"
CE-216B-HR: 11"

* CE-216-HR can be used for both CEILINGs and WALLPANELS.

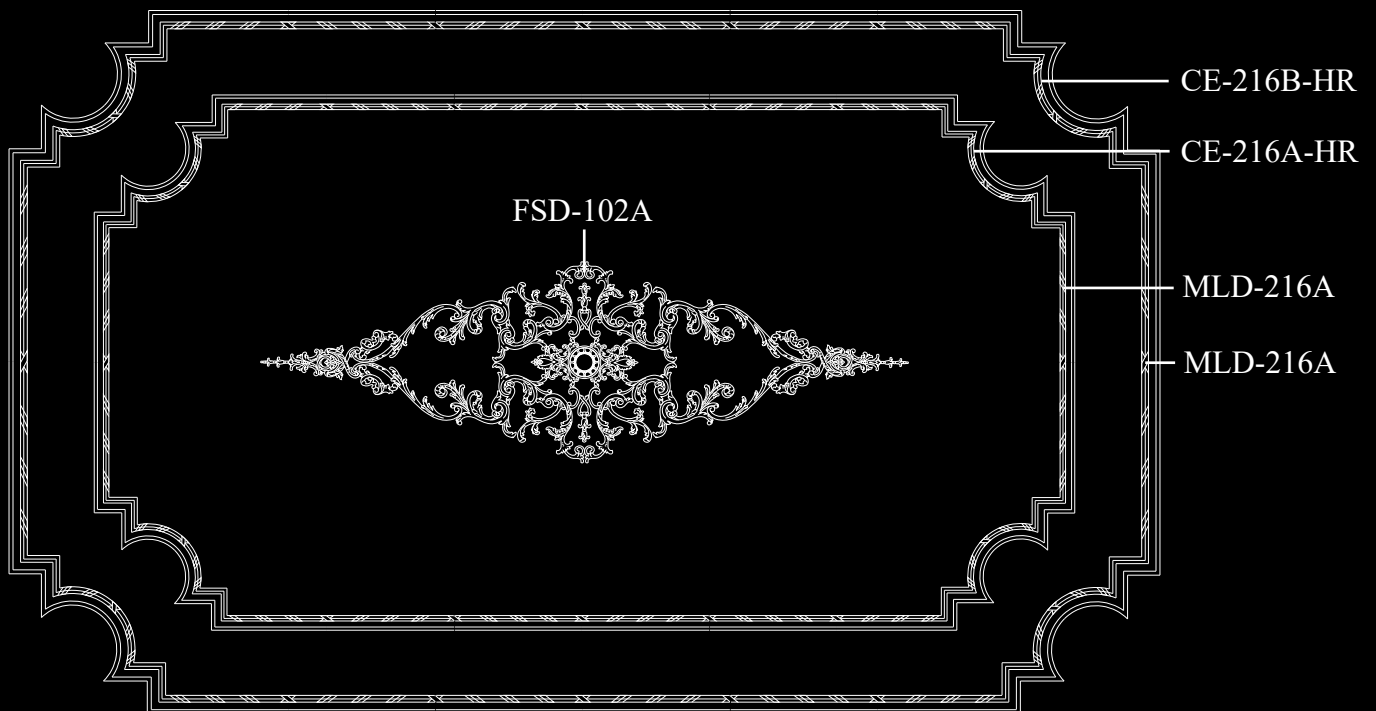

CORNER ELEMENTS

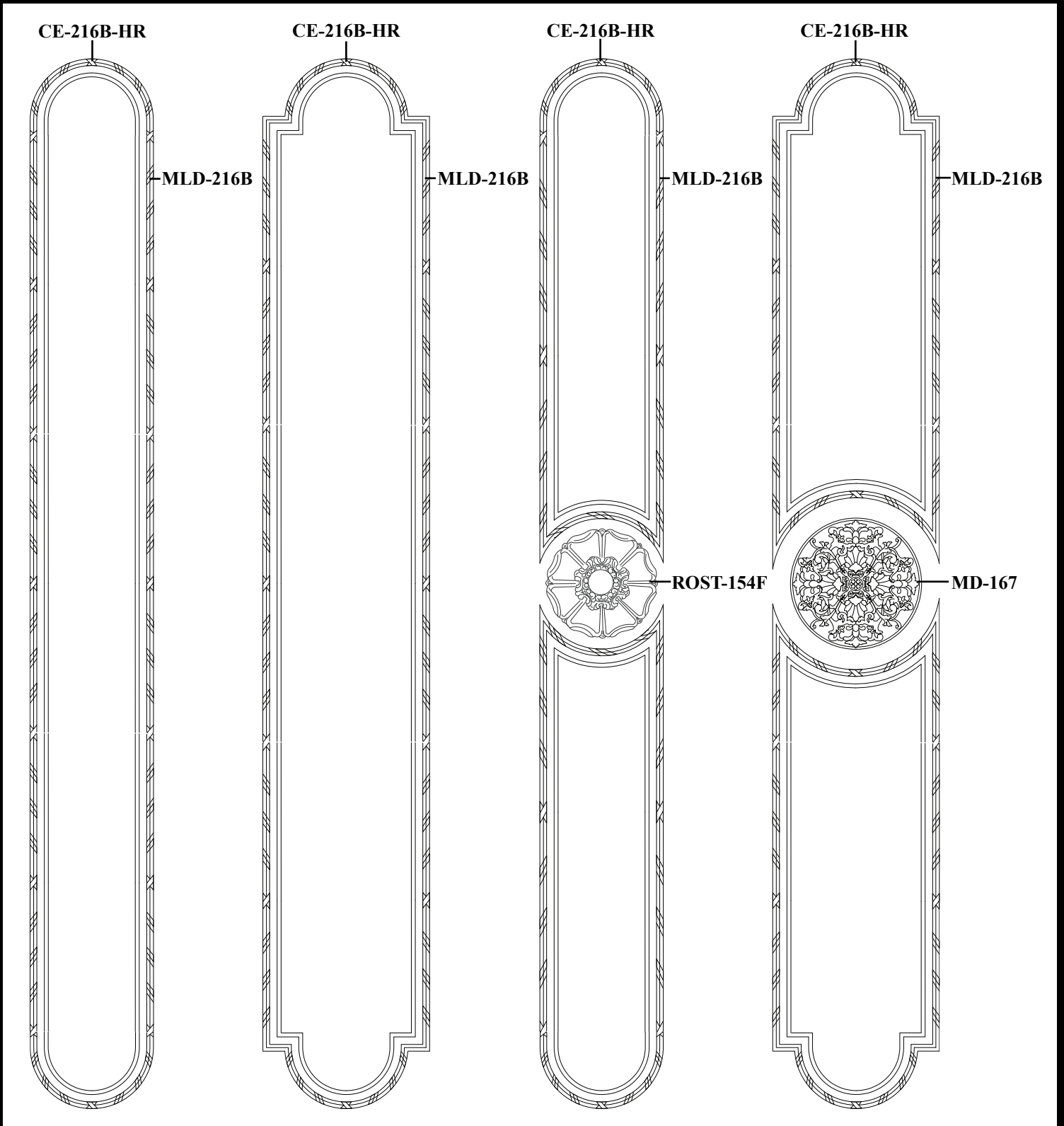

* All sizes are approx.- max W" x max H" x Thickness"

CORNER ELEMENTS

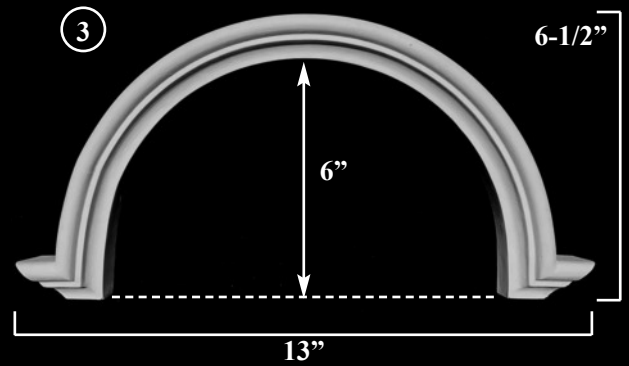
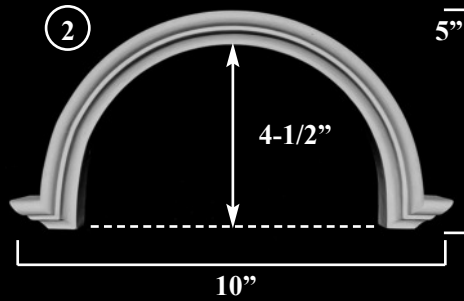
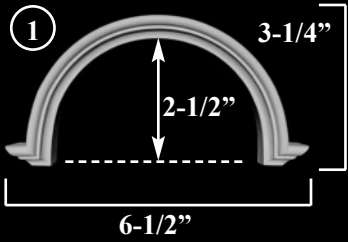

MLD-249L Profile

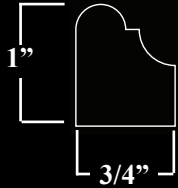

MLD-249L
3/4" x 1" x 10'

* Use MLD-249L for straights.



* CE-249L-OG was designed to be used in a recessed format.

* CE-M249L-OG was made 1" thick for adjustability.

① **CE-249AL-OG**
6-1/2" x 3-1/4" x 1"

② **CE-249BL-OG**
10" x 5" x 1"

③ **CE-249CL-OG**
13" x 6-1/2" x 1"

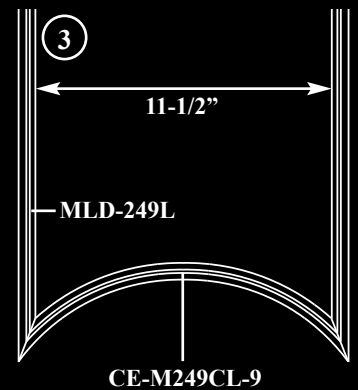
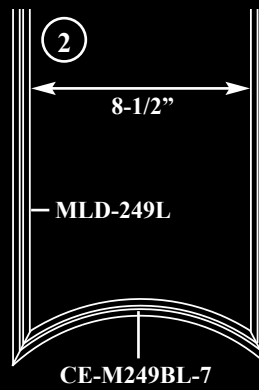
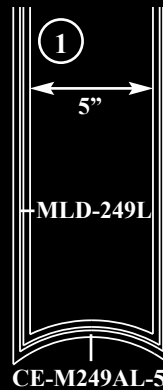
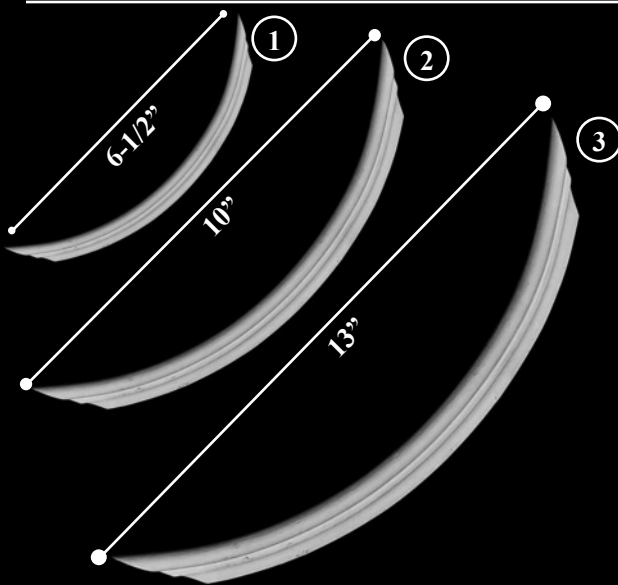

* CE-M249L was designed to be used in a recessed format.

* CE-M249L was made 1" thick for adjustability.

① **CE-M249AL-5**
3/4" x 6-1/2" x 1"

② **CE-M249BL-7**
3/4" x 10" x 1"

③ **CE-M249CL-9**
3/4" x 13" x 1"

MLD-249L Profile

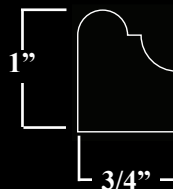

MLD-249L
3/4" x 1" x 10'

* Use MLD-249L for straights.

CORNER ELEMENTS

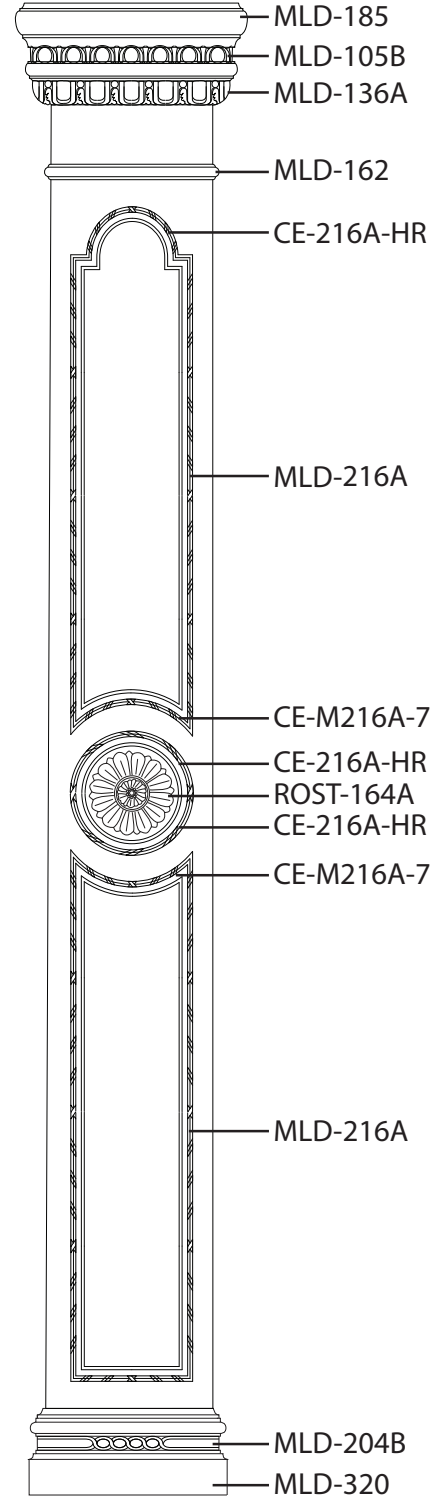
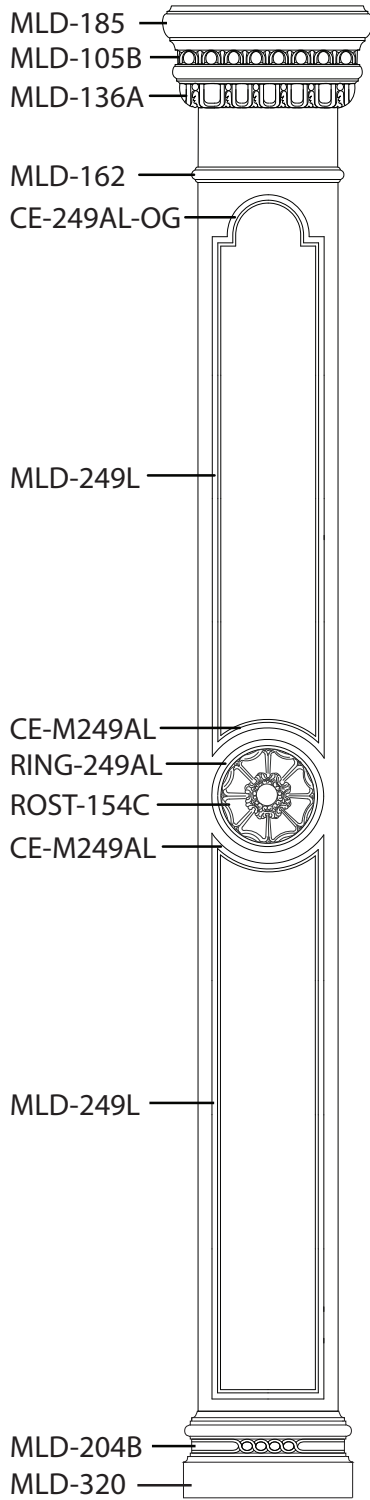

* All sizes are approx.- max W” x max H” x Thickness”

CORNER ELEMENTS (A Size)

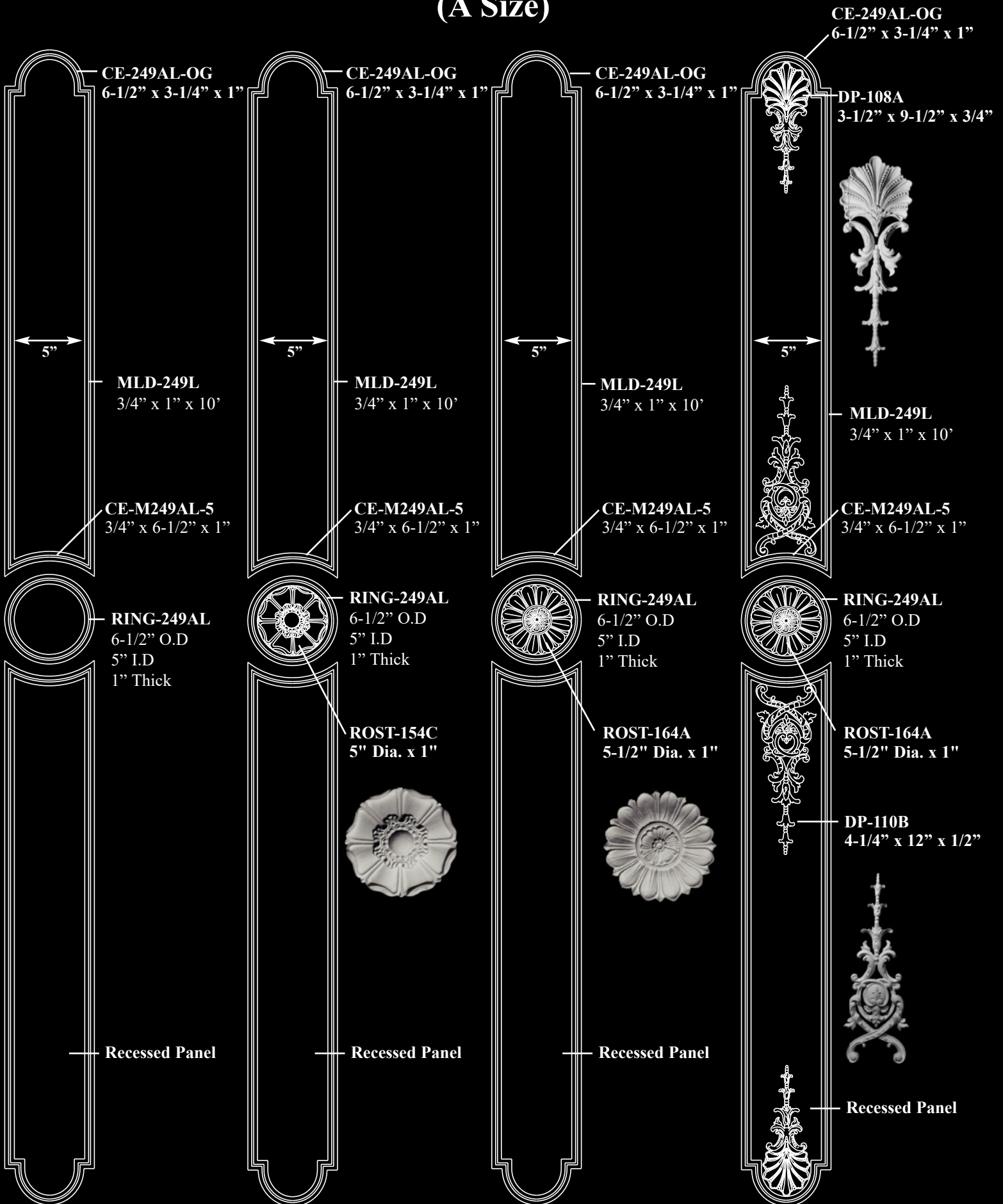

CORNER ELEMENTS (B Size)

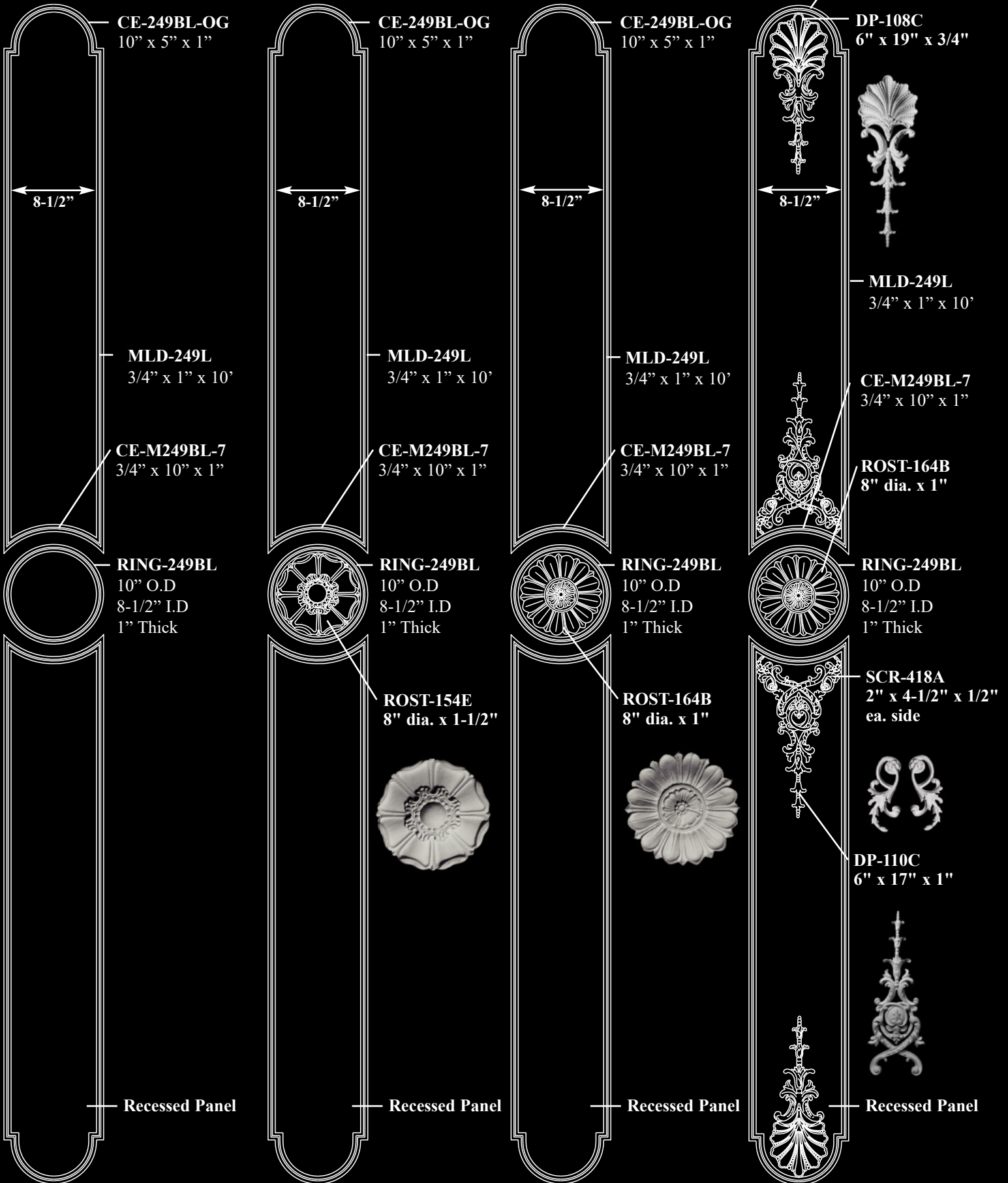



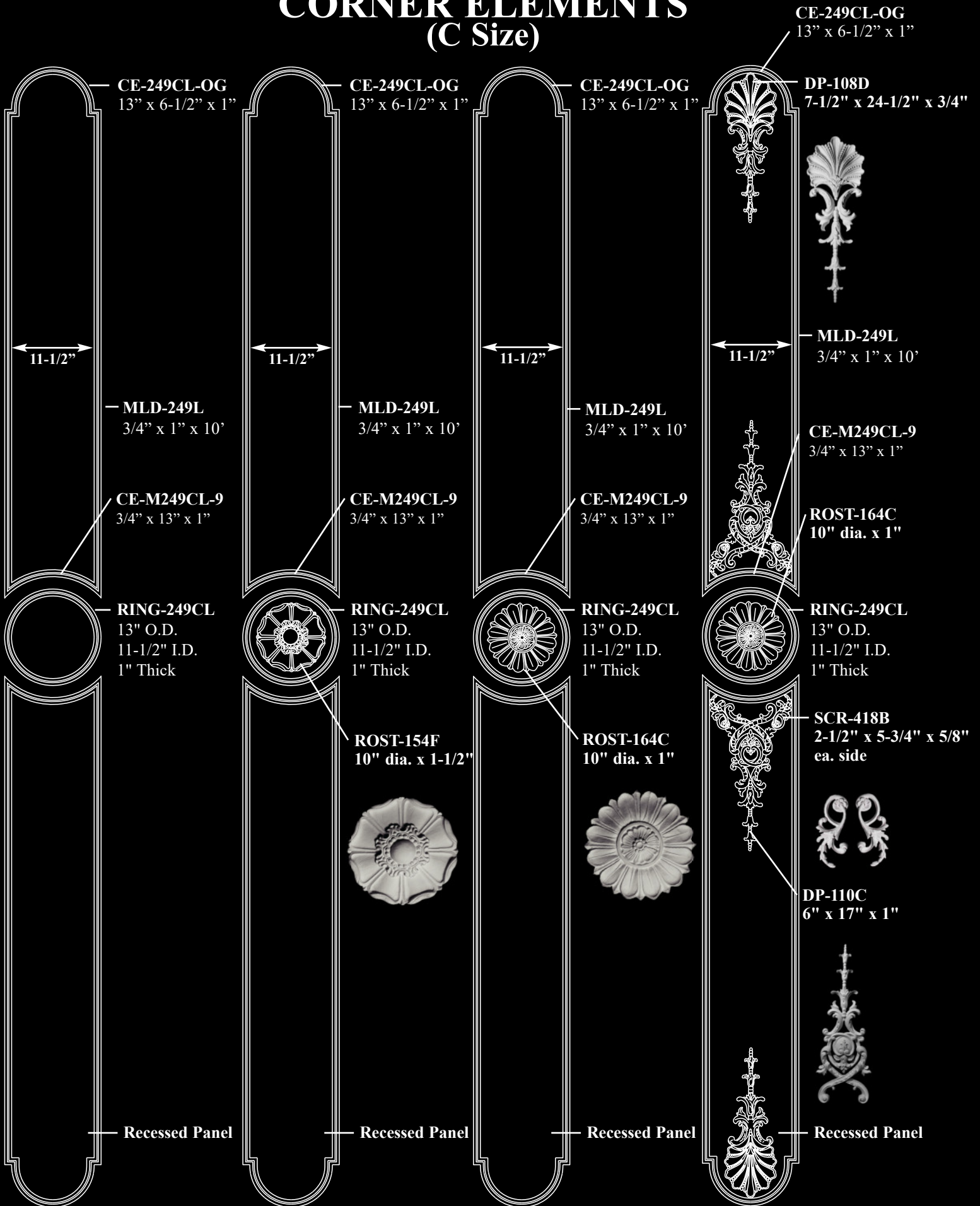

* All sizes are approx.- max W" x max H" x Thickness"

CORNER ELEMENTS (C Size)

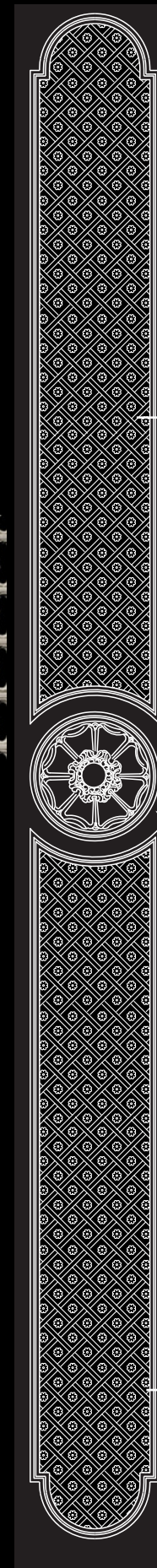

CORNER ELEMENTS

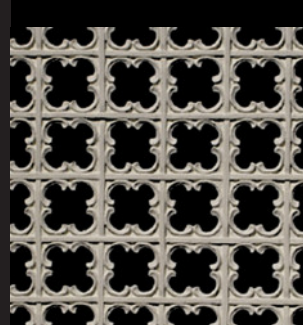
Design Options

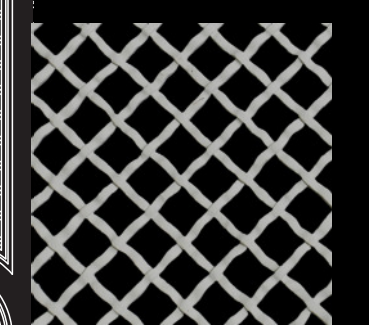
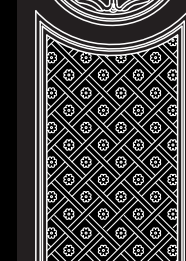
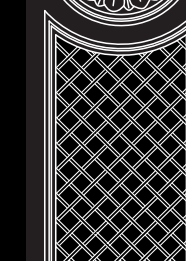
	<p>3 Sizes Available. 6-1/2" O.D. 10" O.D. 13" O.D.</p> <p>PANL-130A 14" x 14" x 3/16"</p>		<p>3 Sizes Available. 6-1/2" O.D. 10" O.D. 13" O.D.</p> <p>PANL-104A 13-1/2" x 13-1/2" x 3/8"</p>		<p>3 Sizes Available. 6-1/2" O.D. 10" O.D. 13" O.D.</p> <p>PANL-105A 13-1/2" x 13-1/2" x 1/4"</p>
	 <p>Panel Close Up</p>		 <p>Panel Close Up</p>		 <p>Panel Close Up</p>
		 <p>ROST-154C 5" Dia. x 1"</p> <p>ROST-154E 8" dia. x 1-1/2"</p> <p>ROST-154F 10" dia. x 1-1/2"</p>		 <p>ROST-164A 5-1/2" Dia. x 1"</p> <p>ROST-164B 8" dia. x 1"</p> <p>ROST-164C 10" dia. x 1"</p>	
	<p>Recessed Panel</p>		<p>Recessed Panel</p>		<p>Recessed Panel</p>

* All sizes are approx.- max W" x max H" x Thickness"

CORNER ELEMENTS

Design Options

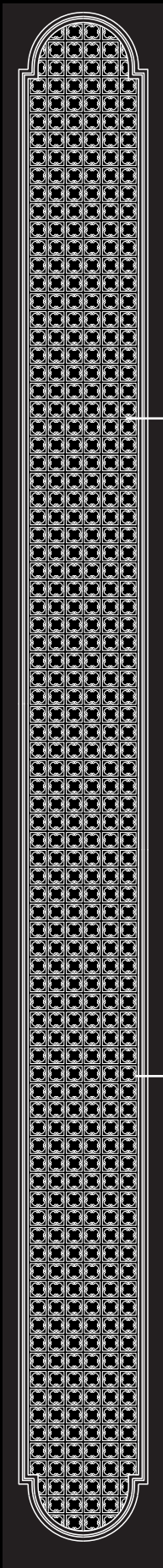

3 Sizes Available.

6-1/2" O.D.

10" O.D.

13" O.D.

PANL-130A

14" x 14" x 3/16"

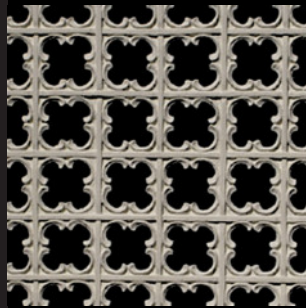

Panel Close Up

Recessed Panel

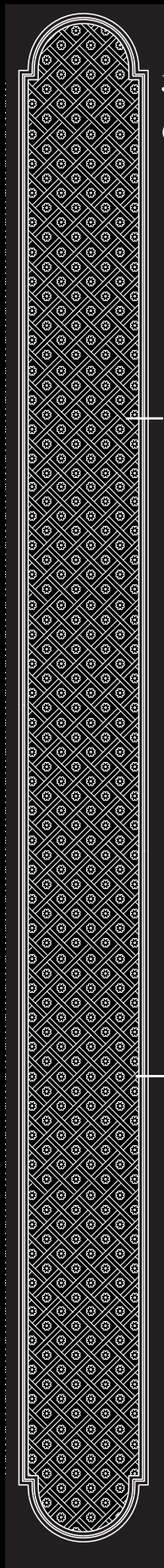

3 Sizes Available.

6-1/2" O.D.

10" O.D.

13" O.D.

PANL-104A

13-1/2" x 13-1/2" x 3/8"

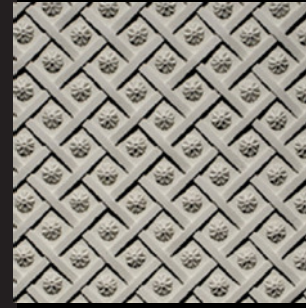

Panel Close Up

Recessed Panel

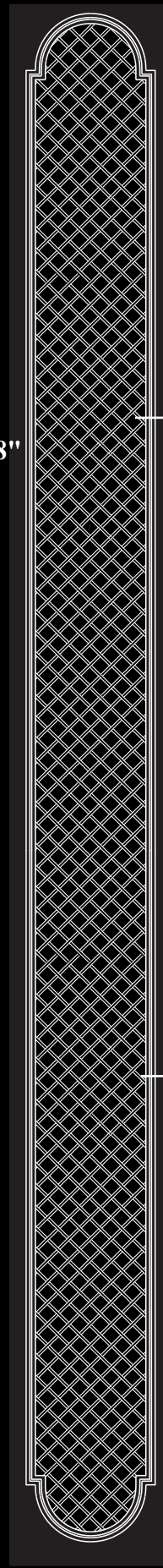

3 Sizes Available.

6-1/2" O.D.

10" O.D.

13" O.D.

PANL-105A

13-1/2" x 13-1/2" x 1/4"

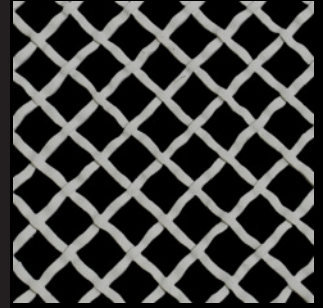

Panel Close Up

Recessed Panel

CORNER ELEMENTS



* All sizes are approx.- max W” x max H” x Thickness”

CROWN MOULDING CORNER ELEMENTS



CE-300A Coming Soon.
Designed for 3-1/2" and 4" crown moulding

CE-300B 4-3/4" x 4-3/4" x 13-1/2"
Designed for 6" and 6-1/2" crown moulding

CE-300C Coming Soon.
Designed for 7-1/2" to 8-1/2" crown moulding

CE-300D Coming Soon.
Designed for 10" crown moulding

* Sold as a 3 piece set

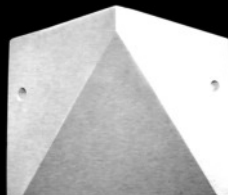

Crown moulding must be installed at a standard 45° Angle

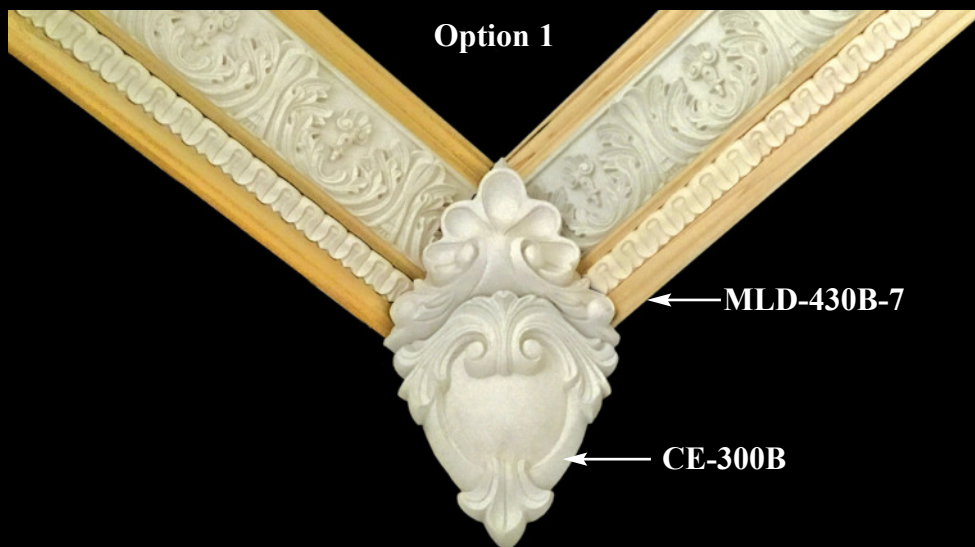

Option 1

MLD-430B-7

CE-300B

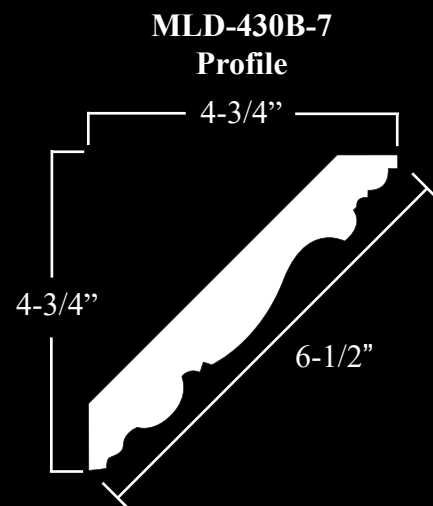

MLD-430B-7
Profile



Option 2
Mount corner element on
surface of inside corner.

Optional Profile
Moulding

MLD-213C

SCR-426C

MLD-F-301

CE-300B

Optional Profile
Moulding

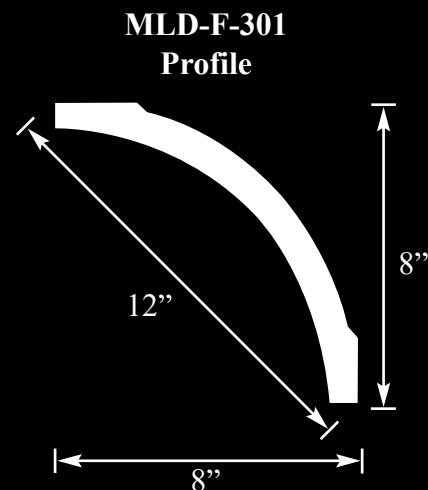

MLD-F-301
Profile

CROWN MOULDING CORNER ELEMENTS



CORNER ELEMENTS

* All sizes are approx.- max W" x max H" x Thickness"

COVE MOULDING CORNER ELEMENTS

22"

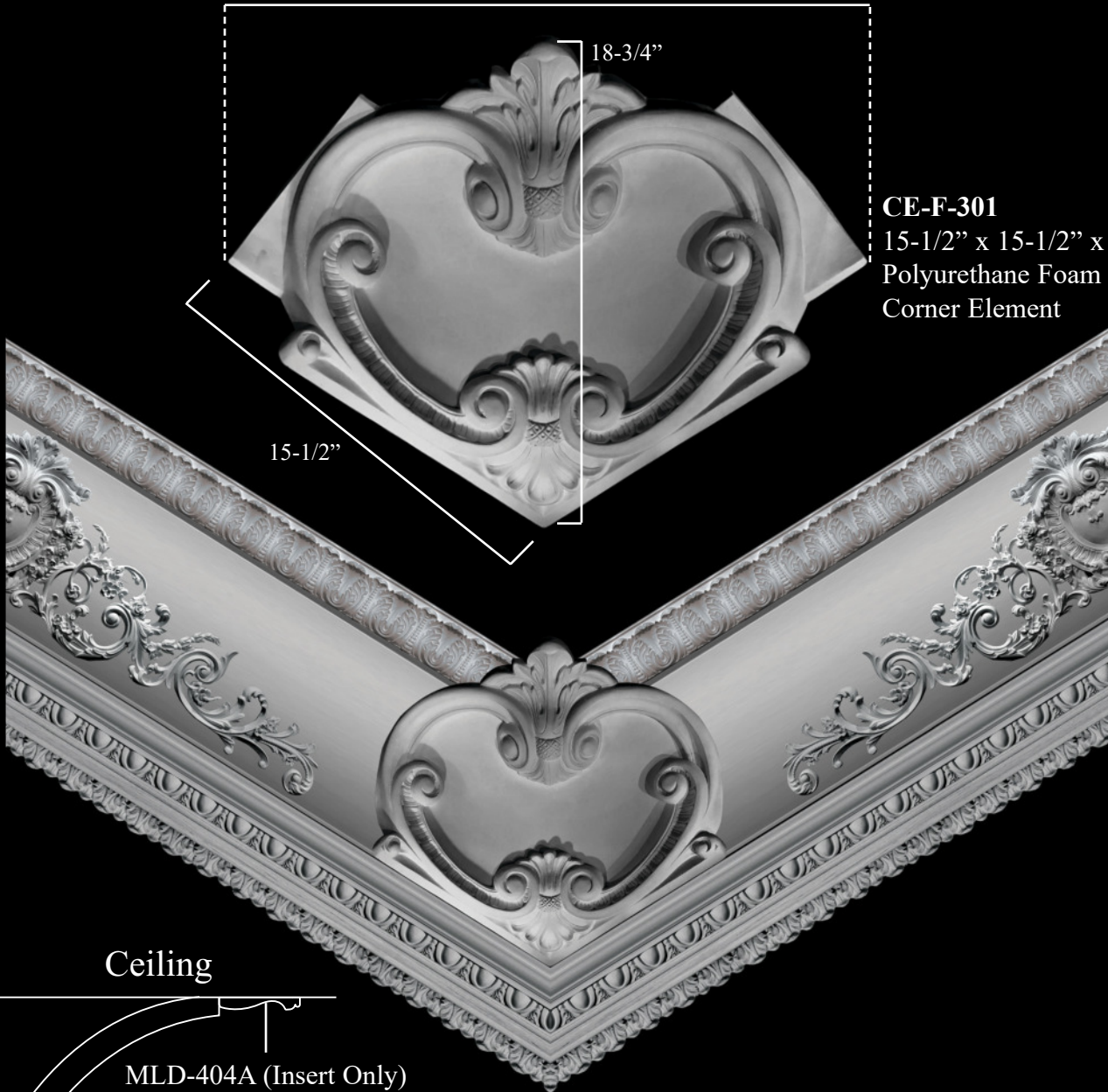

CE-F-301
15-1/2" x 15-1/2" x 8-1/4"
Polyurethane Foam
Corner Element

Ceiling

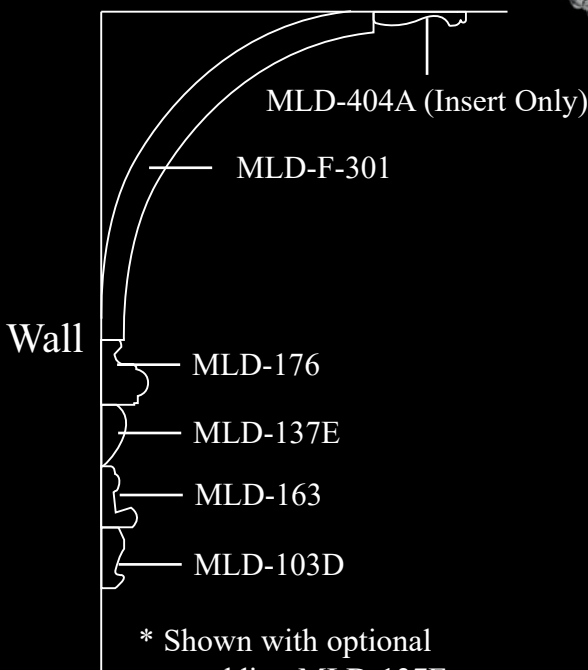

Pearlworks has just produced its first radius cove ceiling corner elements. These corner elements are very unique in that they are produced in a light weight polyurethane material. Polyurethane material can be installed by any competent carpenter using standard woodworking tools and adhesives. A typical four corner room will take a crew of two carpenters 1 to 3 days for the installation.

Plaster ceilings require weeks to install by specialist who only do plaster. Most plaster companies are either on the east coast or mid west which requires these crews to fly to the job site, requiring hotel rooms and living expenses. These added labor and time increases can easily triple the cost.

Today these issues are a thing of the past and this new line has opened up an incredible look at a very affordable price and an ease of installation that has never been seen before.

COVE MOULDING CORNER ELEMENTS

CT-123 54" x 12" x 1-1/4"

Flexible Resin

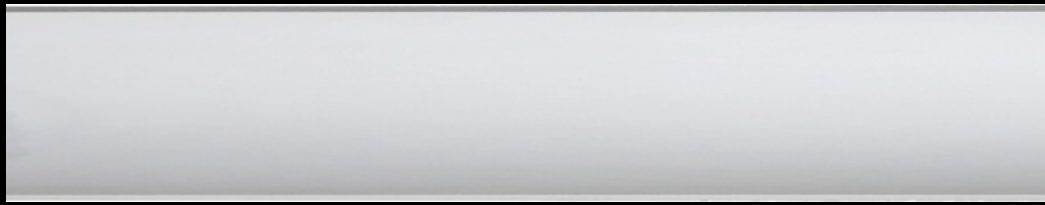
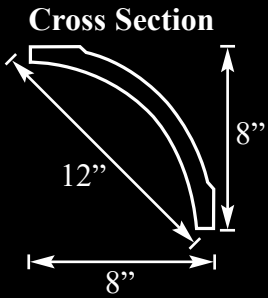

MLD-F-301 12" x 2-3/4" x 95"
Polyurethane

Cove moulding not flexible.

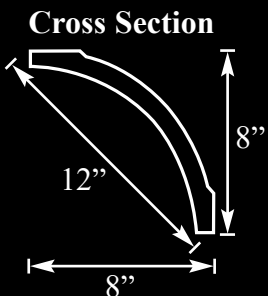

*Cartouche installed Separately

MLD-F-301A 12" x 3-3/4" x 95"
Sold as a 2 piece set.

Cove moulding not flexible.

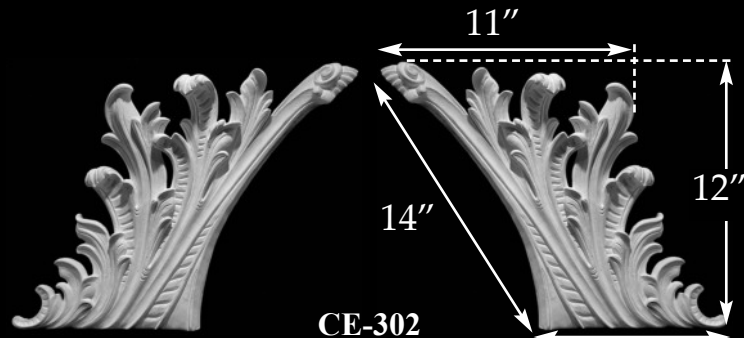
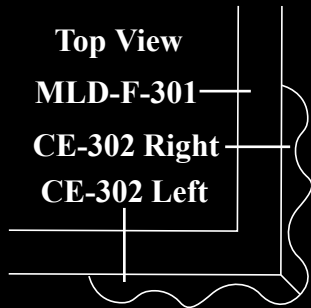

CE-302

9" x 14" x 1" Average Thickness 9"
Sold As Left And Right Set

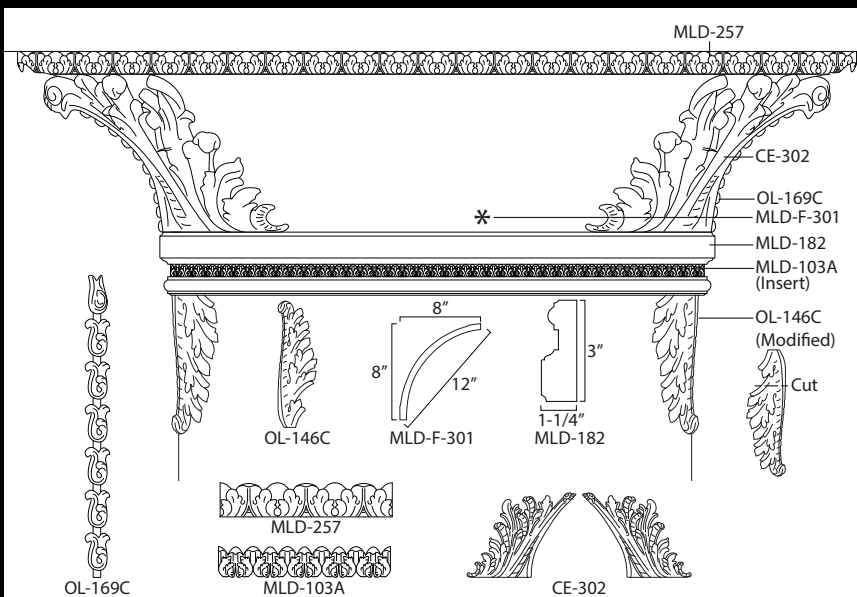

CORNER ELEMENTS

* All sizes are approx.- max W" x max H" x Thickness"

CORNER ELEMENTS



* All sizes are approx.- max W" x max H" x Thickness"

CORNER ELEMENTS

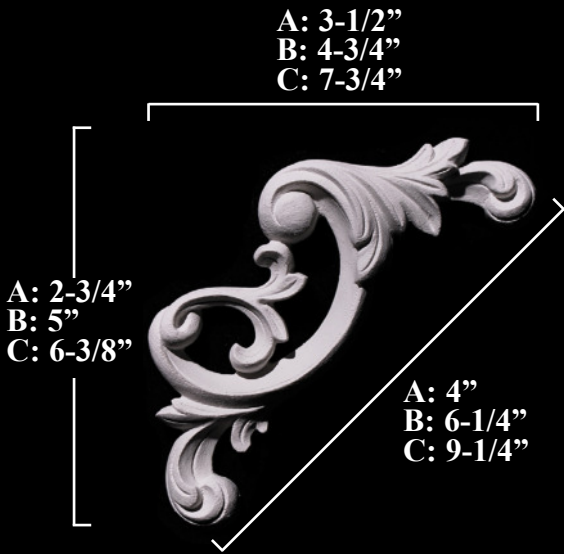

Sold As Left and Right Pair

CE-305A

3-1/2" x 2-3/4" x 3/8" Ea. Side

CE-305B

4-3/4" x 5" x 1/2" Ea. Side

CE-305C

7-3/4" x 6-3/8" x 5/8" Ea. Side

Any 1/2" - 5/8" wide connection moulding will work with CE-305A.

* Most popular designs for CE-305A.



Any 1/2" - 3/4" wide connection moulding will work with CE-305B.

* Most popular designs for CE-305B.



Any 3/4" - 1" wide connection moulding will work with CE-305C.

* Most popular designs for CE-305C.

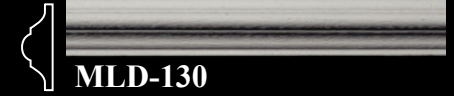

* All sizes are approx. - max W" x max H" x Thickness"

CORNER ELEMENTS



Sold As
L and R Pair

CE-306C
4-1/2" x 10" x 1" Ea. Side

Any 1-1/2" - 2" wide connection
moulding will work with CE-306C.

* Most popular designs for CE-306C.



MLD-111E



MLD-119EL



MLD-139E



MLD-171

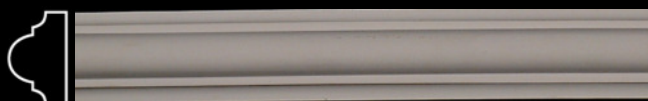

MLD-177B



MLD-212D

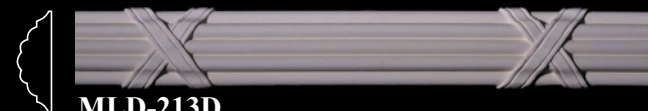

MLD-213D

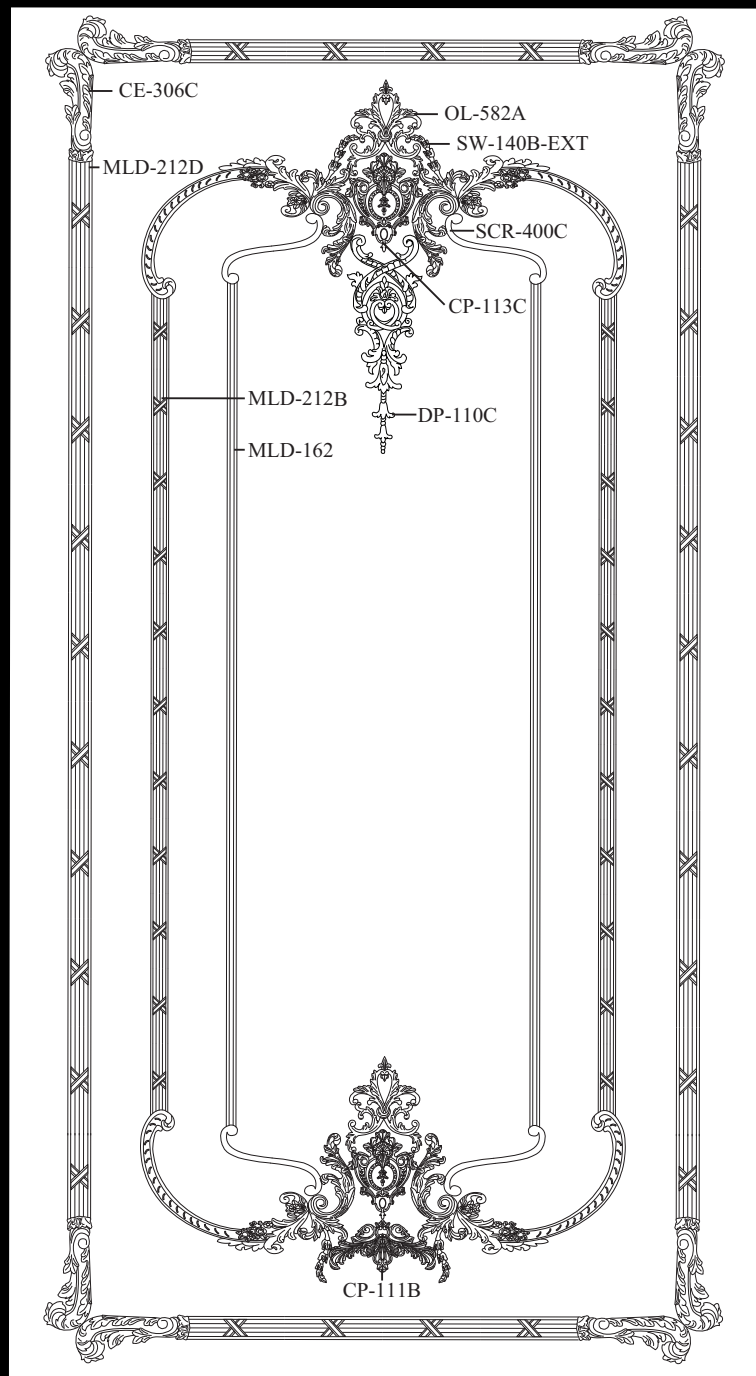

Sold As L and R Pair

CE-307
9-3/4" x 8-5/8" x 1-1/4" Ea. Side

CORNER ELEMENTS



CE-310AA
 4-1/2" x 4-1/2" x 3/8"
 Designed for COLM-130AA

CE-310A
 7-1/4" x 7-1/4" x 1/2"
 Designed for COLM-130A

CE-310B
 10-1/4" x 10-1/4" x 5/8"
 Designed for COLM-130B

CE-310C
 12-1/2" x 12-1/2" x 5/8"
 Designed for COLM-130C

CE-310D
 17-1/2" x 17-1/2" x 3/4"
 Designed for COLM-130D



CE-310AA: 1-1/4" Width

CE-310A: 2" Width

CE-310B: 3" Width

CE-310C: 3-1/4" Width

CE-310D: 3-3/4" Width

CORNER ELEMENTS



Sold as Left and Right Pair

CE-311A
3-3/4" x 3" x 1/2"

CE-311C
6" x 5" x 1/2"

CE-311B
4-3/4" x 4" x 1/2"

CE-311D
7-3/4" x 6-1/2" x 3/4"



Our Inspiration



CE-312
52" x 52" x 1"
Sold as a 10 piece Set.
Designed for use with
(Cove Moulding) MLD-F-301.

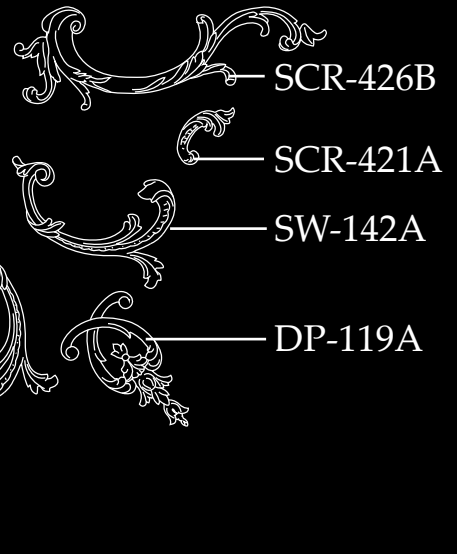

CORNER ELEMENTS

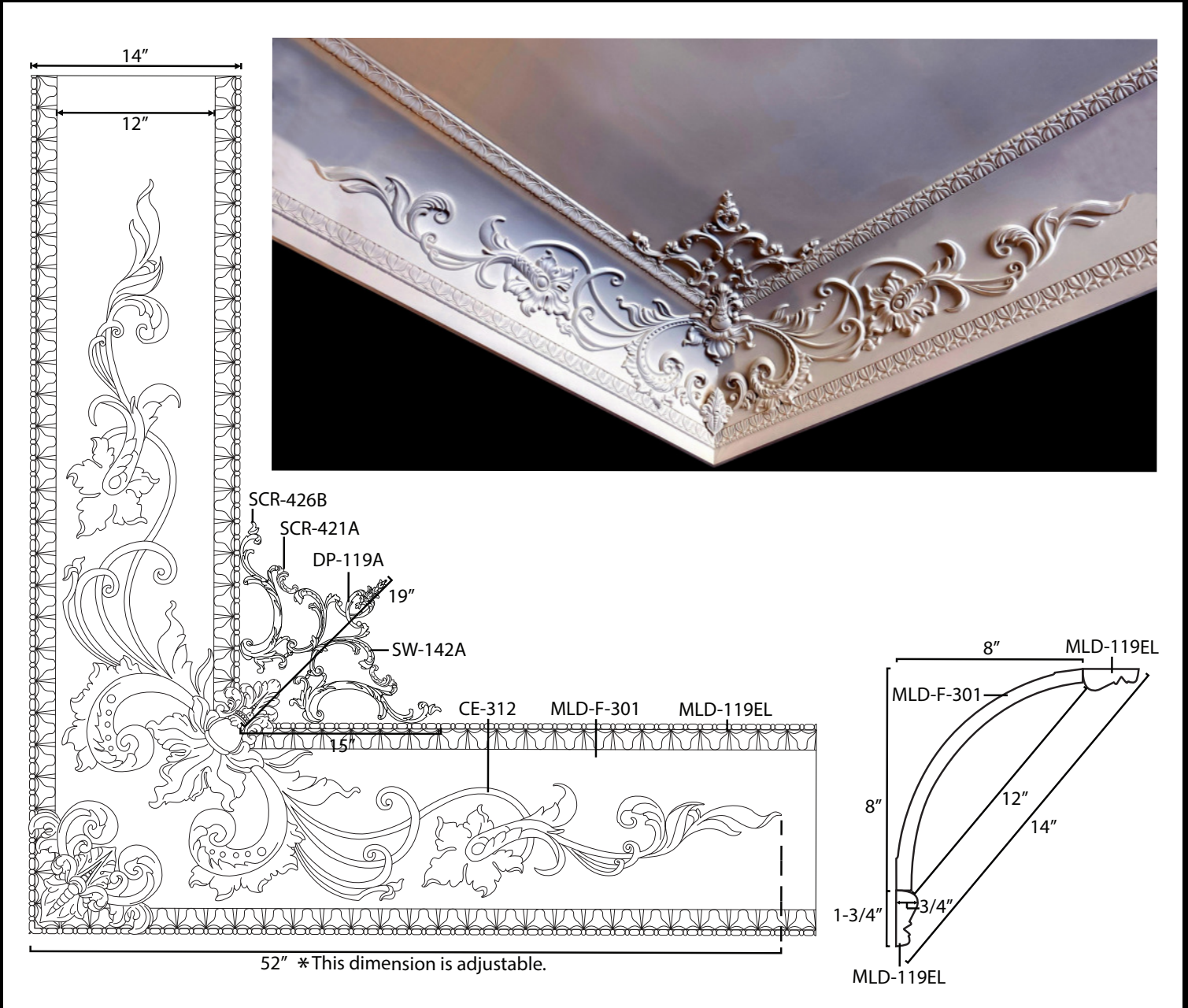

* All sizes are approx.- max W" x max H" x Thickness"

Wall or Ceiling Panel Concepts

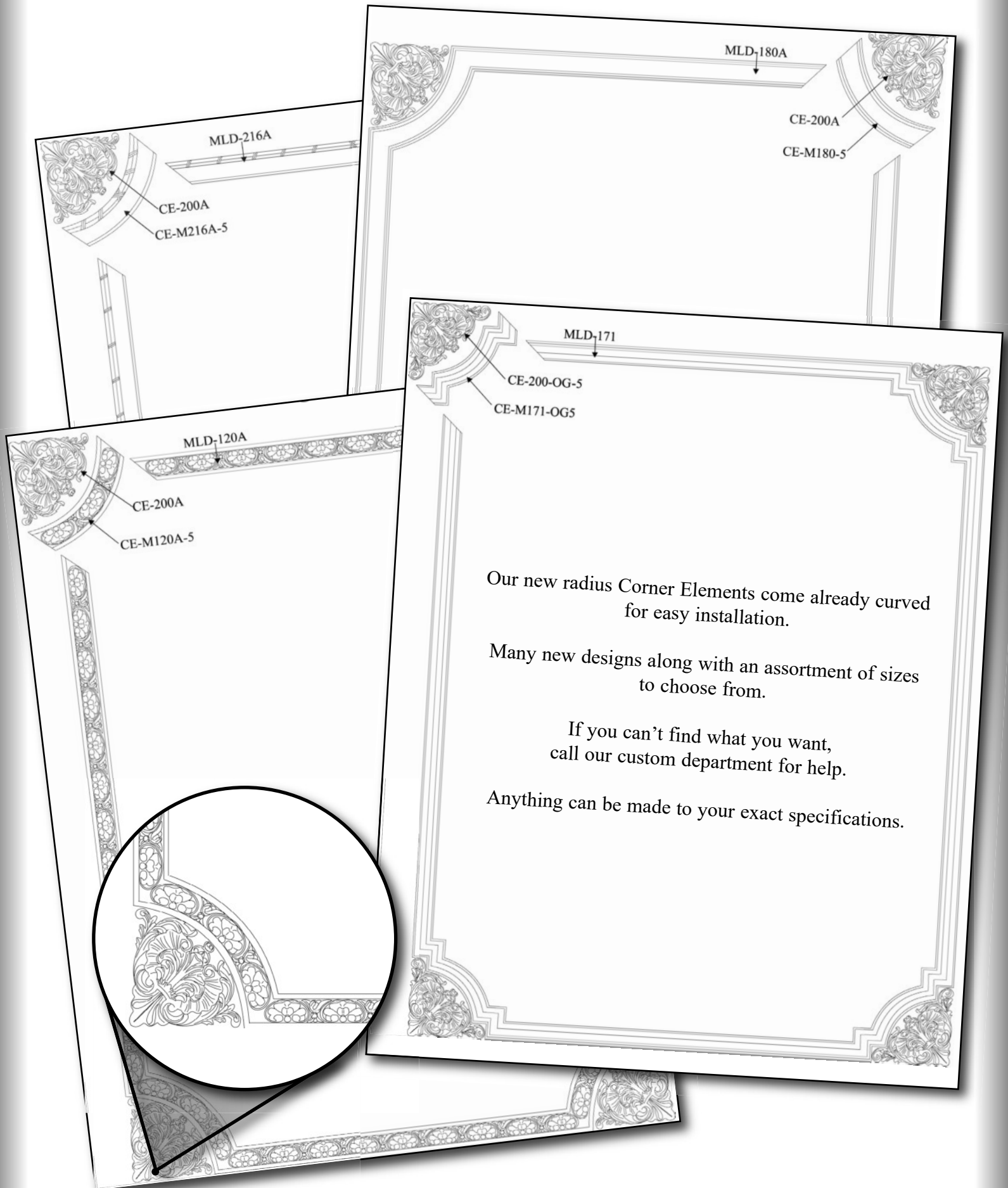

Our new radius Corner Elements come already curved for easy installation.

Many new designs along with an assortment of sizes to choose from.

If you can't find what you want, call our custom department for help.

Anything can be made to your exact specifications.

Wall or Ceiling Panel Concept

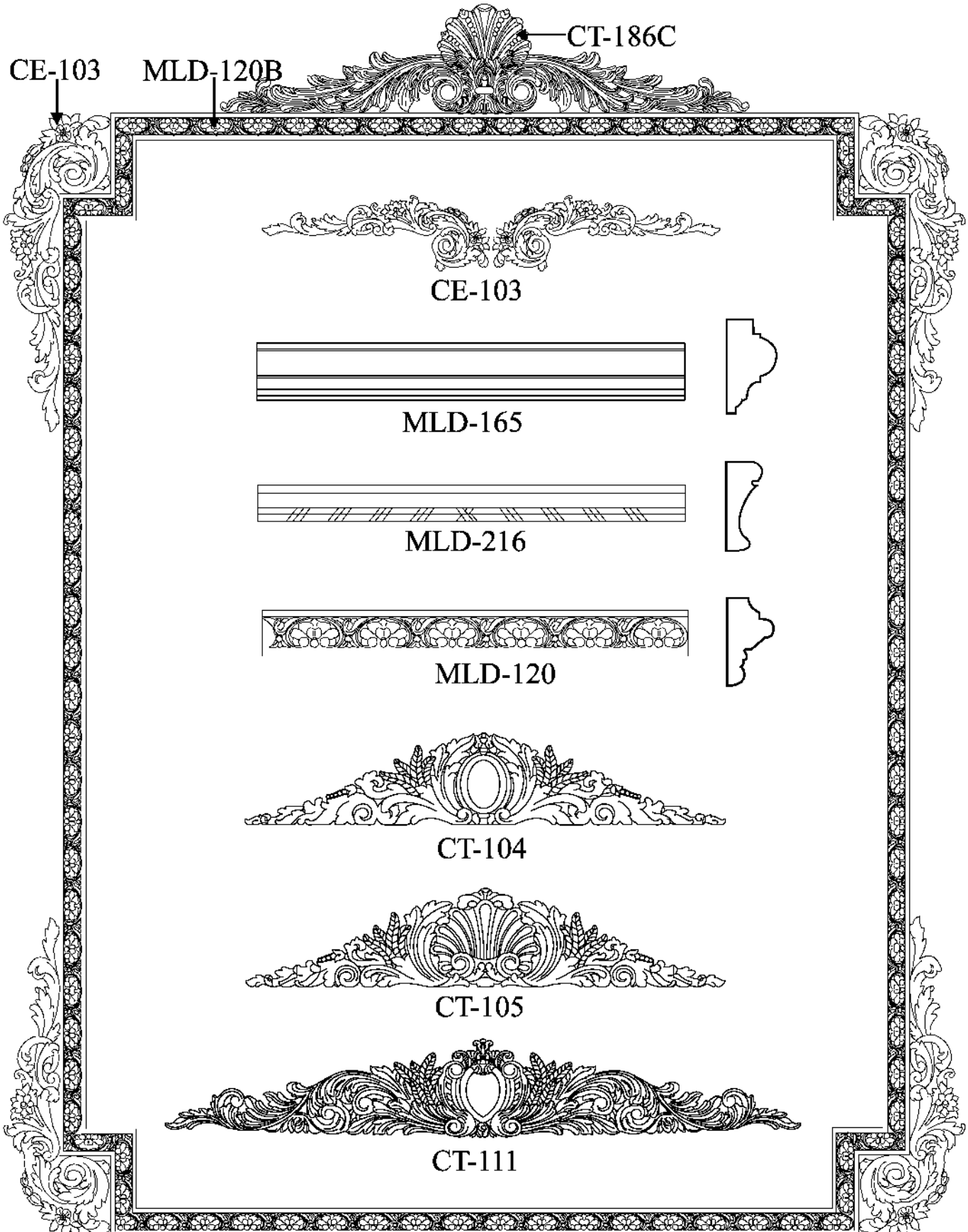

* Our modular system allows the following options to create many exciting designs.

* All sizes are approx.- max W" x max H" x Thickness"

Wall Panel Concept



As shown: 26" Wide (CE-108 is adjustable for a wider width)

**Part of our Versailles Wall Panel Collection. Part #: VSC-26
Assembly size (as shown): 26" W x 30-1/4" H x 1" Thick
(CE-108 is adjustable for a wider width)**

CORNER ELEMENT PRICE LIST

#	Part Number	Price
1	CE-100A	\$34.95
2	CE-100B	\$43.95
3	CE-101	\$38.95
4	CE-102	\$34.95
5	CE-103	\$175.95
6	CE-104A	\$34.95
7	CE-104B	\$43.95
8	CE-105	\$24.95
9	CE-107	\$179.95
10	CE-108A	\$87.95
11	CE-108A-EXT	\$98.95
12	CE-109A	\$18.95
13	CE-109B	\$27.95
14	CE-109C	\$38.95
15	CE-110A	\$24.95
16	CE-110B	\$32.95
17	CE-110C	\$38.95
18	CE-110D	\$49.95
19	CE-120A	\$24.95
20	CE-120B	\$32.95
21	CE-120C	\$43.95
22	CE-120D	\$49.95
23	CE-129	\$34.95
24	CE-130A	\$38.95
25	CE-130B	\$43.95
26	CE-131A	\$21.95
27	CE-131B	\$32.95
28	CE-131C	\$43.95
29	CE-131D	\$54.95
30	CE-131E	\$76.95
31	CE-131F	\$109.95
32	CE-132	\$6.95
33	CE-133	\$43.95
34	CE-134A	\$4.95
35	CE-134B	\$6.95
36	CE-134C	\$10.95

#	Part Number	Price
37	CE-135A	\$4.95
38	CE-135B	\$6.95
39	CE-135C	\$10.95
40	CE-136	\$10.95
41	CE-137AA	\$9.95
42	CE-137A	\$14.95
43	CE-137B	\$21.95
44	CE-138A-EXT	\$39.95
45	CE-138A	\$34.95
46	CE-138B	\$43.95
47	CE-138C	\$54.95
48	CE-139	\$24.95
49	CE-140	\$19.95
50	CE-141A	\$29.95
51	CE-141B	\$54.95
52	CE-141C	\$98.95
53	CE-142A	\$21.95
54	CE-142B	\$32.95
55	CE-142C	\$43.95
56	CE-143	\$24.95
57	CE-145A	\$76.95
58	CE-145B	\$98.95
59	CE-145C	\$120.95
60	CE-151A	\$109.95
61	CE-151A-1	\$38.95
62	CE-151A-2	\$38.95
63	CE-151A-3	\$38.95
64	CE-151A-4	\$38.95
65	CE-151A-5	\$32.95
66	CE-151A-6	\$32.95
67	CE-151A-7	\$32.95
68	CE-151B	\$131.95
69	CE-151B-1	\$43.95
70	CE-151B-2	\$43.95
71	CE-151B-3	\$43.95
72	CE-151B-4	\$43.95

#	Part Number	Price
73	CE-151B-5	\$38.95
74	CE-151B-6	\$38.95
75	CE-151B-7	\$38.95
76	CE-151B-7	\$38.95
77	CE-160A	\$98.95
78	CE-160A-EXT	\$109.95
79	CE-200-OG-5	\$49.95
80	CE-200-OG-7	\$60.95
81	CE-200A	\$11.95
82	CE-200B	\$13.95
83	CE-200C	\$21.95
84	CE-200D	\$27.95
85	CE-200DD	\$38.95
86	CE-200DL	\$27.95
87	CE-200E	\$43.95
88	CE-200EL	\$43.95
89	CE-201A	\$76.95
90	CE-201B	\$164.95
91	CE-216A-HR	\$24.95
92	CE-216B-HR	\$29.95
93	CE-249AL-OG	\$27.95
94	CE-249BL-OG	\$32.95
95	CE-249CL-OG	\$38.95
96	CE-300B	\$164.95
97	CE-302	\$219.95
98	CE-305A	\$13.95
99	CE-305B	\$21.95
100	CE-305C	\$32.95
101	CE-306C	\$65.95
102	CE-307	\$49.95
103	CE-310AA	\$19.95
104	CE-310A	\$24.95
105	CE-310B	\$29.95
106	CE-310C	\$34.95
107	CE-310D	\$44.95
108	CE-311A	\$15.95

CORNER ELEMENT PRICE LIST

#	Part Number	Price
109	CE-311B	\$23.95
110	CE-311C	\$26.95
111	CE-311D	\$29.95
112	CE-312	\$419.95
113	CE-F-301	\$439.95
114	CE-M110	\$76.95
115	CE-M110-2	\$7.95
116	CE-M110-3	\$8.95
117	CE-M110-4	\$9.95
118	CE-M110-5	\$10.95
119	CE-M110-6	\$12.95
120	CE-M110-7	\$14.95
121	CE-M113B-7	\$23.95
122	CE-M120A-5	\$27.95
123	CE-M120A-7	\$32.95
124	CE-M120B-7	\$40.95
125	CE-M123VS-7	\$32.95
126	CE-M160A-5	\$20.95
127	CE-M160A-7	\$23.95
128	CE-M160B-5	\$24.95
129	CE-M160B-7	\$27.95
130	CE-M162-3	\$9.95
131	CE-M162-4	\$10.95
132	CE-M162-5	\$11.95
133	CE-M162-7	\$14.95
134	CE-M164AL	\$27.95
135	CE-M164BL	\$28.95
136	CE-M164CL	\$43.95
137	CE-M165A-5	\$20.95
138	CE-M165A-7	\$25.95
139	CE-M171-5	\$16.95
140	CE-M171-7	\$21.95
141	CE-M171-OG-5	\$23.95
142	CE-M171-OG-7	\$27.95
143	CE-M173-5	\$26.95

#	Part Number	Price
144	CE-M173-7	\$27.95
145	CE-M174-5	\$26.95
146	CE-M174-7	\$27.95
147	CE-M180A-5	\$27.95
148	CE-M180A-7	\$38.95
149	CE-M180A-OG-5	\$38.95
150	CE-M180A-OG-7	\$43.95
151	CE-M213B-3	\$38.95
152	CE-M213B-4	\$40.95
153	CE-M213B-5	\$42.95
154	CE-M213B-6	\$44.95
155	CE-M213B-7	\$48.95
156	CE-M216A-3	\$16.95
157	CE-M216A-5	\$20.95
158	CE-M216A-7	\$27.95
159	CE-M216B-5	\$21.95
160	CE-M216B-7	\$27.95
161	CE-M216C-7	\$32.95
162	CE-M249AL-5	\$16.95
163	CE-M249BL-7	\$21.95
164	CE-M249CL-9	\$27.95